

®



DSX-1022 UL Hardware Installation Manual

April 2024

Part # UL1022Manual Rev B

This page was intentionally left blank.

Compliance Information

This equipment was tested and found to comply with the limits for a Class A digital device, pursuant to part 15 of the FCC Rules. These limits provide reasonable protection against harmful interference when the equipment is operated in a commercial environment. This equipment generates, uses, and can radiate radio frequency energy. Not installing this equipment in accordance with this instruction manual, may result in harmful interference to radio communications. Operation of this equipment in a residential area is likely to cause harmful interference in which case the user will be required to correct the interference at their own expense.

You must consult your local fire codes before installing any locking device on doors, gates, or barriers. A construction and fire approval permit may be required before installing any equipment. Call your local Fire Marshall for building code requirements in your area.

For UL installations, you must install the DSX System according to the UL Installation Manual and in accordance with the National Electric Code, ANSI / NFPA 70 regulations and recommendations for US Installations. Canadian installations must be in accordance with the Canadian Electric Code C22.1.

The DSX-1022, DSX-1040CDM, DSX-1040PDM, DSX-1042, DSX-1043, DSX-1044, DSX-CKI-C, DSX-CKI-K, DSX-DP485 and DSX-FRB8 have been tested and found to conform to the requirements of UL 294 8th Edition.

The DSX-1022, DSX-1040CDM, DSX-1040PDM, DSX-1042, DSX-1043, DSX-1044, DSX-1040-PE-B, DSX-MCI, DSX-LAN, DSX-SPS and DSX-2PC have been tested and found to conform to the requirements of UL 1076.

The following card readers have been tested by UL for compatibility with DSX equipment: Essex DS-12, HID ID-MP5365, HID W-S, Mercury MR-10, Motorola ASR-503 and TimeKeeping Systems TKS-110.

Information contained within this document was known to be true at the time of printing. This information is subject to change any time without notice.

DSX is a registered trademark of DSX Access Systems Inc, WinDSX is a trademark of DSX Access Systems Inc.

The use of or reference to the term's AMP, American Fibertek, AptiQ, Astrodyne, AT&T, Basler, Belden, CardKey, CasiRusco, Checkpoint, Communications Specialties, Cotag, Digi-Key, Dorado, DS, Easkey, Essex, HID Corporation, Hughes, Indala, Ingersol Rand, International Fiber Systems, Interstate, Keri, Kronos, Lantronix, Microsoft, Motorola, Northern, Panasonic, Powersonic, Pyramid Associates, Radionics, Readykey, Rusco, SecuraKey, Sentrol, Sensor Engineering, Time Keeping Systems TKS, Windows, Windows NT, Windows 2000, Windows XP and Windows Vista may or may not be the registered trademarks of the respective companies.

This document is a team effort by the Technical Support and Engineering Group at DSX Access Systems, Inc.

All DSX manufactured products are warranted against defects in materials and workmanship for two (2) years from date of shipment. Products not manufactured by DSX are warranted for one (1) year. DSX Access Systems, Inc., will repair or replace products that prove defective and are returned to DSX freight prepaid within the warranty period. The foregoing warranty shall not apply to defects resulting from misuse, accident, alteration, neglect, improper installation, unauthorized repair, or Acts of Nature. DSX shall have the right of final determination as to the existence and causes of the defect.

No other warranty, whether written or oral is expressed or implied.

Table of Contents

System Overview	1
Typical System Configuration.....	3
1022 Controller Features	4
Typical Wiring Diagram.....	3
1022E Enclosure Specifications	6
AC Power Connections	7
Battery Connections	8
Ground Connections.....	9
Diagnostic and Trouble LEDs	10
Fuse Ratings and Locations.....	11
Cable Specifications	12
UL Requirements	14
1022 Controller Addressing	16
Switch Definitions	16
Location Address (Master).....	16
Device Address (Sub).....	16
Typical Address Settings.....	17
Chart of Address Settings 0-63.....	18
Chart of Address Settings 64-127.....	19
Inputs.....	21
Characteristics	21
Status LEDs.....	21
Input 7 Door Position Switch	21
Input 8 Exit Request.....	22
Abort Delay Time.....	22
Panel Tamper.....	22
Two, Three, and Four State Monitoring.....	22
Door Lock and Input Timing.....	24
Outputs	25
Status LEDs.....	25
Surge Suppression MOVs	25
Inputs 7, 8 and Output 1 Wiring.....	26
Pre-Alarm Output (a.k.a. Pre-Warn).....	27
PC Bound Direct Communications	28
RS-485.....	28
Controller to Controller Communications.....	29
Master to Sub Communications Charts	30
Sub to Sub Communications Charts.....	31
DSX-1035 Quadraplexor.....	32
Master or Sub to DSX-1035 Communications Charts.....	34
AptiQ™ Proximity Readers	35
CardKey™ Readers.....	39
HID™ Proximity Readers	44
HID™ Wiegand Readers.....	48
Indala™/Motorola™ Proximity Readers.....	51
Mercury™ MR10/20 Magnetic Stripe Readers.....	55
Pyramid™ Proximity Readers.....	58
Securakey™ Barium Ferrite Readers	59
Time Keeping Systems™ TKS-110	62
Bar Code positioning	63
DSX Keypads.....	65
DSX-DP232 and DSX-485 Surge Suppression.....	69
Field Test Procedures	70
Trouble Shooting.....	71
Routine Maintenance.....	77
Conditions Which May Cause Undesired Operation.....	77

This page was intentionally left blank.

System Overview

The WinDSX System is a PC based site management and monitoring system used to control and monitor personnel and input activity. By making extensive use of distributed processing, the WinDSX System integrates access control, input monitoring, and equipment control into a single system.

The WinDSX System provides different controllers that offer various combinations of card reader and keypad controls, relay outputs, and monitored inputs. The controllers will combine to provide the exact number of inputs and outputs required for the application. All DSX controllers use a fully distributed architecture with real time processing at each DSX controller. By distributing all information (time, date, valid codes, access levels, etc.), the WinDSX System provides some significant advantages.

- ❑ **Instant response to Card Read or Keypad Entry despite system size.**
- ❑ **No degradation of system performance in case of communications loss. All time zones, access levels, and holiday schedules remain operational.**
- ❑ **No loss of transactions for system history files during communication loss. All controllers automatically switch to buffer mode and can store up to thousands of events each.**

Each DSX controller represents one "Intelligent Controller" in the distributed processing network. Each controller uses an AM 186 microprocessor as its engine. Instead of all processing power centralized in one PC it is distributed throughout the system. The processing occurs near each reader, which makes the system more efficient and secure.

Information downloads to the DSX controllers through a PC. The PC is not necessary for system operation and can go off-line once the system information downloads to the controllers. The system PC is simply used as:

- ❑ **Terminal or Window into the system**
- ❑ **History Data Logging Device**
- ❑ **Data Manager**

The WinDSX System will support up to 32,000 separate access control locations from a single PC. Each system maintains its own database and history files and may control up to 64 DSX controllers per location. DSX defines each location as one Master Controller with up to 63 Sub Controllers. Locations can be combined to create a very large local network of controllers or may be maintained separately to control up to 32,000 different buildings with up to 128 card readers and/or keypads at each building.

The first controller of each location is designated as the Master. All subsequent controllers at the location are designated as Subs. Any DSX controller may be designated as the Master by specific dipswitch settings that enable it to work as a Master controller. The Master performs all of the same functions as the Sub controllers but is also responsible for polling Sub controllers and reporting events to the Host PC. The Master controller does not make access control decisions for the Sub controllers. It is simply the messenger for information from the controllers to the PC, and from the PC to the controllers.

Each of the locations may communicate to the PC using various methods. The Master controller can be wired directly to the PC, controlled via dial-up phone modems (modems not tested by UL) or utilize a TCP/IP LAN connection. The Master of a modem-controlled location will automatically buffer all normal transactions until its buffer reaches 80% of capacity. When the buffer reaches 80%, the Master controller initiates a call to the Host PC and uploads all transactions. While the master's transaction buffer is at 80%, all Subs automatically store their own transactions until the Master has uploaded the history to the PC. If an alarm event occurs, the Master controller initiates an immediate call to the PC to report the alarm event. Alternatively, the PC may be programmed to routinely poll each of the remote modem locations and collect the history logs automatically.

The WinDSX system maintains full feature capability regardless of the style of communications with the PC. Both remote modem-controlled locations and direct connect/LAN locations are capable of features such as global input to input and input to output linking, floor select elevator control, global and zoned anti-passback, HVAC control, and lighting control.

All DSX controllers have a built-in dead man reset timer (watchdog circuit) that will automatically reboot the processor if its operation is interrupted due to a transient surge. When the processor is reset, it automatically requests a parameter download from the Master and reboots to its proper working state. If the Master controller is reset, it automatically requests a parameter download from the PC. When the Master is a modem location, it will dial the PC via the modem and receive the parameter download automatically.

Typical System Configuration

The following diagram depicts 4 PCs connected using a Local Area Network, managing three DSX Locations. One PC is the Database Server where the shared database and history files reside. Another PC is the Comm Server which includes a DSX-USB connection for panel communications. The third and fourth PCs are Workstation PCs, which at the very least have administrative only or full capabilities depending on the User Login. Location 1 is shown with a DSX-USB. Location 2 and 3 is shown connecting through a DSX-LANs. Location 1 includes an IN plus an OUT reader along with a Time Display Module to allow the collection of Time and Attendance Reports. Location 3 includes elevator control. This is just a few of the application possibilities.

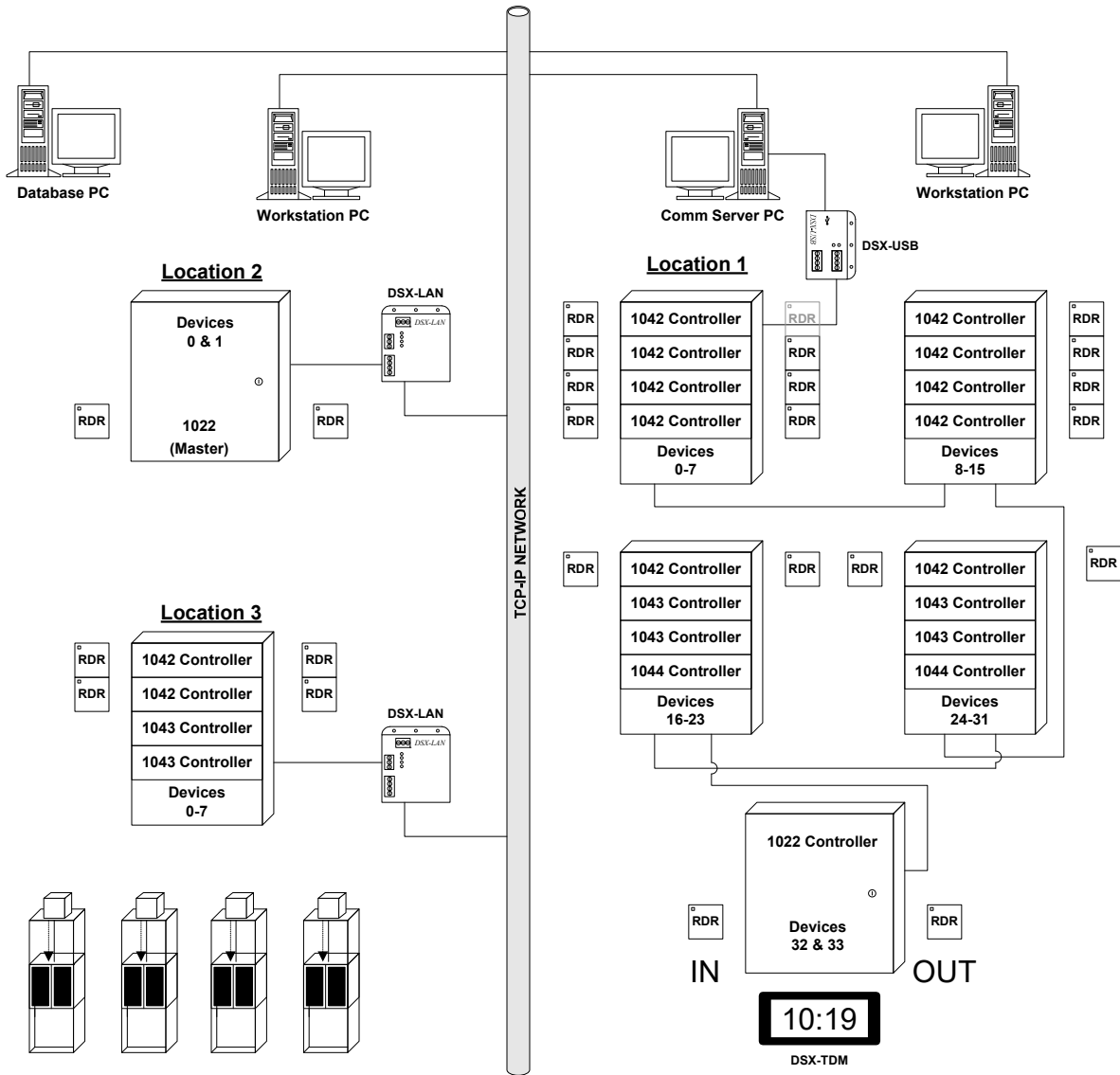

DSX-1022 Controller Features

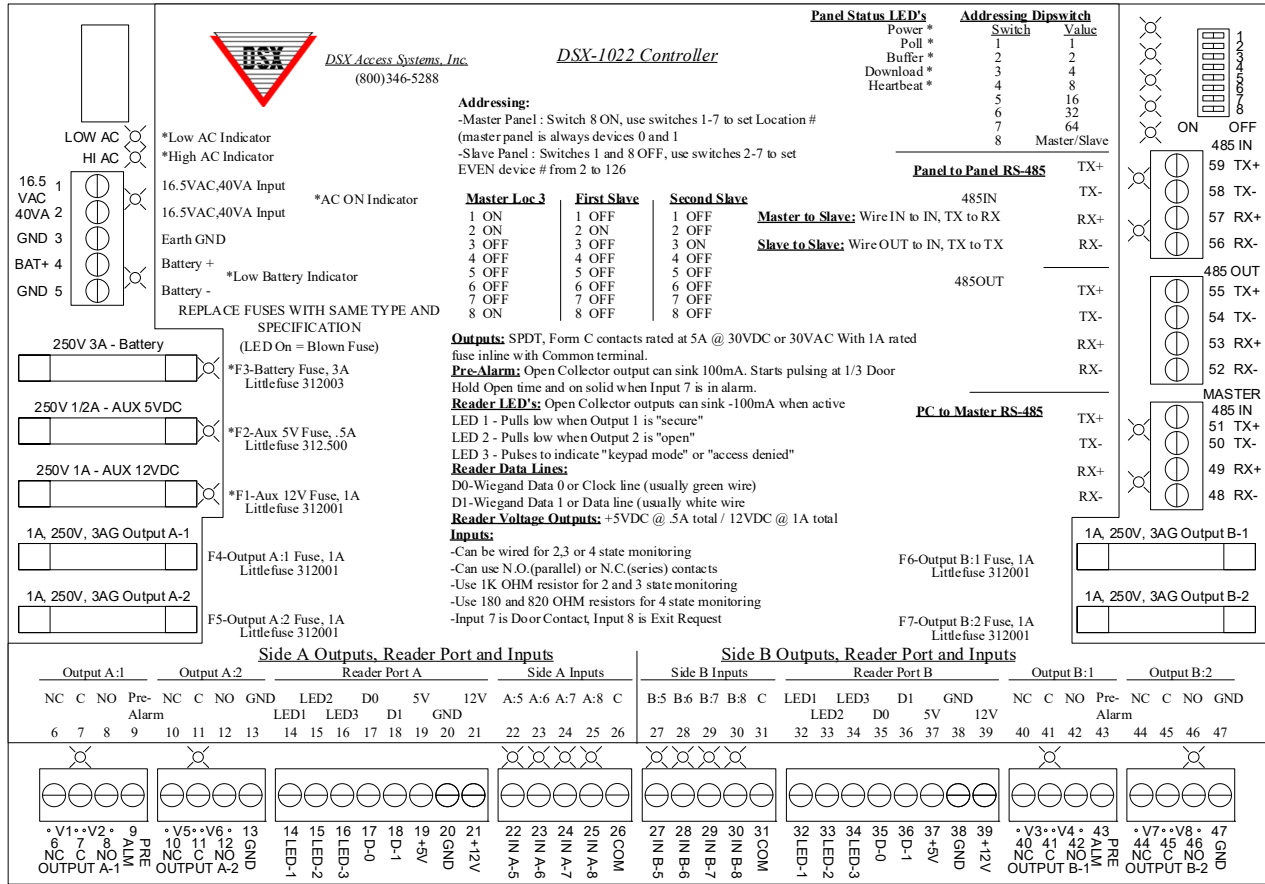

Hardware Feature	Quantities	Description
Reader/Keypad Ports	2	Supports Wiegand, RS-422, and Clock and Data
Reader/Keypad LED Outputs	6	Open Collector – 100ma switched negative
Relay Outputs	4	SPDT 5A@30VDC or 30VAC with 1A inline fuses.
PreWarn Outputs	2	Open Collector – 100ma for Door Held Open
12VDC Output	2	12VDC fused at 1A – Shared between both ports
5VDC Output	2	5VDC fused at 1/2A – Shared between both ports
Inputs (Supervised)	8	Accept NO and/or NC with individual Status LEDs
Status LEDs	28	Blown Fuse, Input, Output, Communications, and Processor Status LEDs
Master to PC Communications	1	RS-485 9600Baud 8-1-N, 2 twisted pair
Sub Communications	2	RS-485 In/Out 9600Baud 4000 feet – 2 twisted pair
Battery Charging Circuit	1	12VDC 7AH Battery minimum 1
Power Input	1	16.5 40VA Transformer

DSX-1022 Typical Wiring Diagram

CAUTION: INCORRECT WIRING MAY RESULT IN DAMAGE TO THE UNIT.

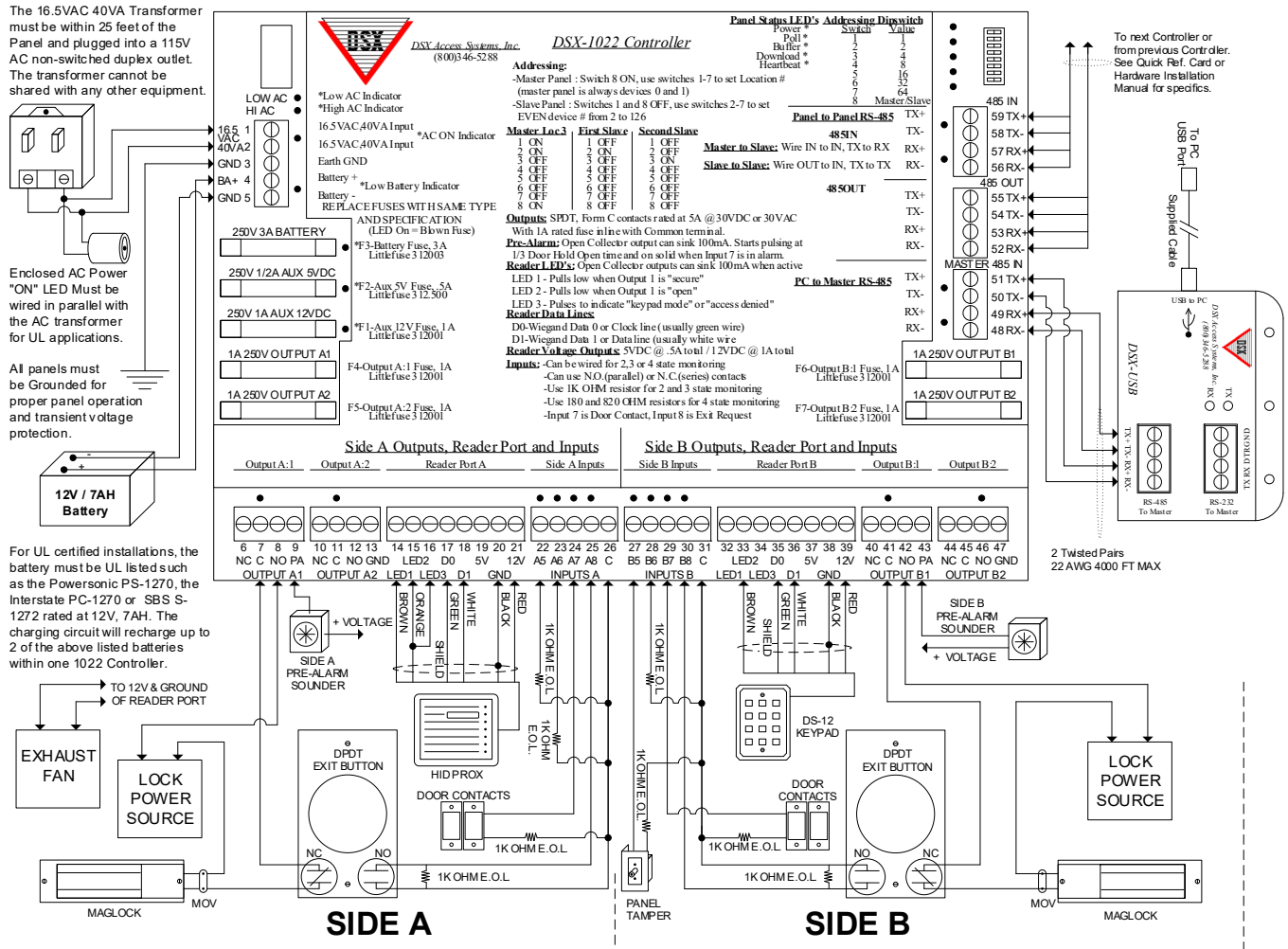

The 16.5VAC 40VA Transformer must be within 25 feet of the Panel and plugged into a 115V AC non-switched duplex outlet. The transformer cannot be shared with any other equipment.

Enclosed AC Power "ON" LED Must be wired in parallel with the AC transformer for UL applications.

All panels must be Grounded for proper panel operation and transient voltage protection.

For UL certified installations, the battery must be UL listed such as the Powersonic PS-1270, the Interstate PC-1270 or SBS S-1272 rated at 12V, 7AH. The charging circuit will recharge up to 2 of the above listed batteries within one 1022 Controller.

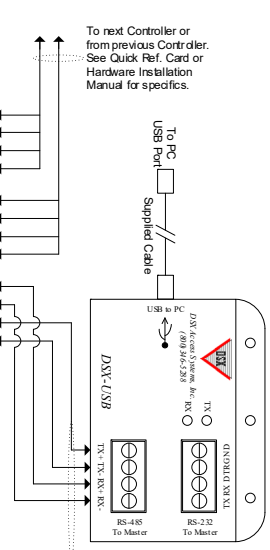
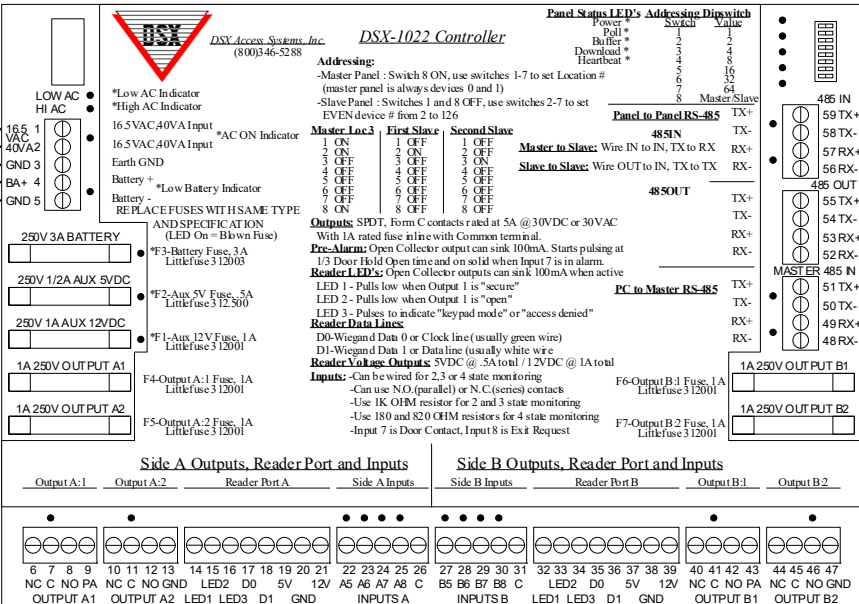

Reader Connection Definitions:
Pre-Alarm connection is an open collector capable of -100mA DC current. Pre-Alarm normally connects to a sounder located near a controlled door to indicate a door has been held open too long.
LED 1 provides (-100mA) to the Reader Secure LED when "Secure".
LED 2 provides (-100mA) to the Reader Open LED when "Open".
LED 3 provides 2 (-100mA) pulses to the Reader Access Denied LED when there is an "Access Denied" condition.
DATA 0 provides a Data 0 or "Clock" signal to the controller.
DATA 1 provides a Data 1 or "Data" signal to the controller.
+5VDC provides up to 5VDC rated at 500mA to power Readers.
NEGATIVE aka GND provides the Reader with a Ground.
+12VDC provides 12VDC rated at 1A to power Readers.
 Note: The +12VDC connection also can be used to provide voltage to other components, such as the DSX Modem. This power supply is shared between the Side A and the Side B Reader Ports.

MOV Usage: If voltages higher than 50 volts are to be switched through the Output relay contact, the individual MOV's (V1&V2, V3&V4, V5&V6 or V7&V8) should be removed from the specific Output.

Panel LED Definitions:
POLL Flashes at a Slave to indicate Comm. to Master panel.
BUFEER is On to indicate panel is storing all history events.
DOWNLOAD is On to indicate the panel is being programmed by the Master.
HEARTBEAT Flashes to indicate the panel is operating.
AC LED is On to indicate AC voltage is present.
LOW AC is On when the AC at panel is approx. 15V or lower.
LOW BATTERY is On when battery voltage drops to approx. 11.5V or lower.
INPUT LEDs are On to indicate the input is normal.
OUTPUT LEDs are On when the relay coil is energized.

Input Circuit Types:
Type 0 - Can monitor NO and/or NC switches, req. 1k Ohm EOL, no Trouble.
Type 1 - Can monitor NC switches, req. 1k Ohm EOL, Sensor open = Alarm, Circuit short = Trouble.
Type 2 - Can monitor NO switches, req. 1k Ohm EOL, Sensor short = Alarm, Circuit open = Trouble.
Type 3 - Can monitor NC switches, req. 180 and 820 Ohm EOLs, Sensor open = Alarm, Circuit open = Trouble, Circuit short = Trouble.
Type 4 - Can monitor NO switches, req. 180 and 820 Ohm EOLs, Sensor closed = Alarm, Circuit open = Trouble, Circuit short = Trouble.

Output Type:
Output Relays Provide Form C, Dry Contact, SPDT, rated at 5A at 30VDC or 30VAC. Contacts provided include NO, C, NC. Each Output Relay includes a 1A fuse inline with the Common terminal.

Output Extender: Use the DSX-0X4 to provide 4 additional Form-C Output Relays. One Extender can connect to a DSX-1022 at the Master (485 IN) port of a SLAVE CONTROLLER. (Required Terminations include TX-RX, RX-TX & +12VDC & GND).

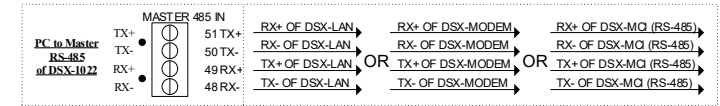

DSX-1022 Enclosure Specifications

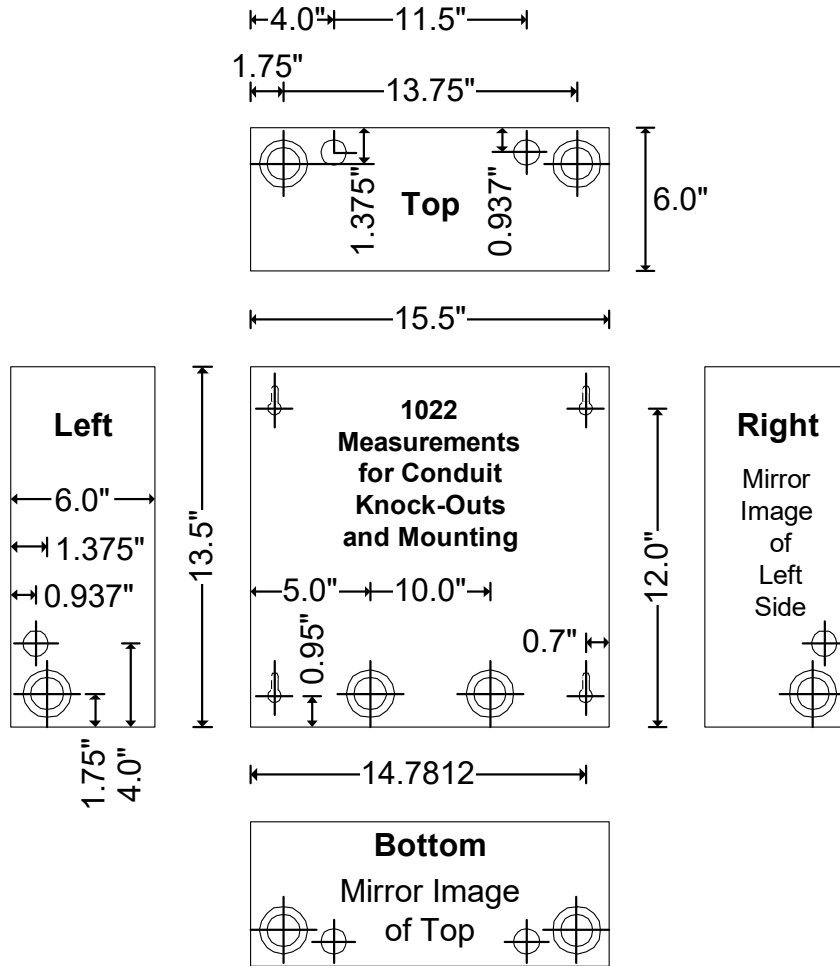

Legend		Conduit Sizes
	SMALLEST	3/4"
	INNER	1"
	OUTER	1 1/2"

AC Power Connections

AC Input

The AC input requires a 16.5 VAC 40VA Class 2 plug-in Transformer. A UL Listed transformer must be used. DSX recommends the Revere Industries, Cat. No. RT-1640SL/M. This transformer is available from DSX. The transformer and the outlet are plugged into should be no more than 25 feet from the controller. The outlet must be on an un-switched electrical circuit. The transformer is connected to the controller using a 18AWG two conductor wire or equivalent. The "AC On LED" must be connected to terminals 1 and 2 of the DSX-1022, in parallel with the wire from the transformer. The DSX-1022 monitors the AC supply for low status and for high status. If the voltage drops below 15 volts or rises above 20 volts, an LED is activated on the controller and a report is sent to the PC if the condition persists for more than 30 seconds. It is important the AC power is within the specified range.

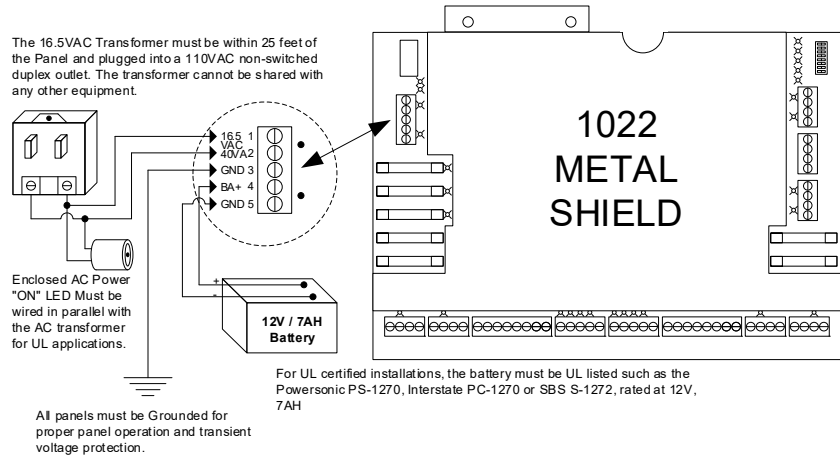

AC Power Test

After all field connections are made to the controller, the AC input voltage should be checked to ensure that the supply voltage to the controller is between 15- and 20-volts AC. This test should be performed with the battery disconnected. When the battery is disconnected, you are assured that the transformer is supplying all the power to the controller. With the battery disconnected, place a 15-ohm 25-Watt resistor on the battery terminals 4 and 5 of the 1022 for one minute. If the Low AC LED illuminates, it indicates that the AC power is running below 15 volts at the controller under load. If the AC power is running low, corrective measures must be taken to raise the supply voltage. If the controller is left operating on low power, the battery will not charge and will drain.

Low AC Voltage

Wrong Transformer - must be 16.5 VAC with a minimum of a 40VA rating.

Long wire run from transformer to controller. In this case, move the transformer closer to the controller, use a larger gauge wire, or use a higher voltage transformer to compensate for the voltage drop in the wire.

Low Voltage at the AC outlet powering the transformer. In this case, move the transformer to an outlet with the proper voltage or replace it with a higher voltage transformer.

High AC Voltage

If AC voltage is above 20 volts at the DSX controller, a lower voltage transformer may be required to correct the problem. If the controller is left operating on high AC voltage, the excess voltage will be dissipated as heat. This heat causes increased stress on the components and could lead to premature failure of the power supply.

Battery Connections

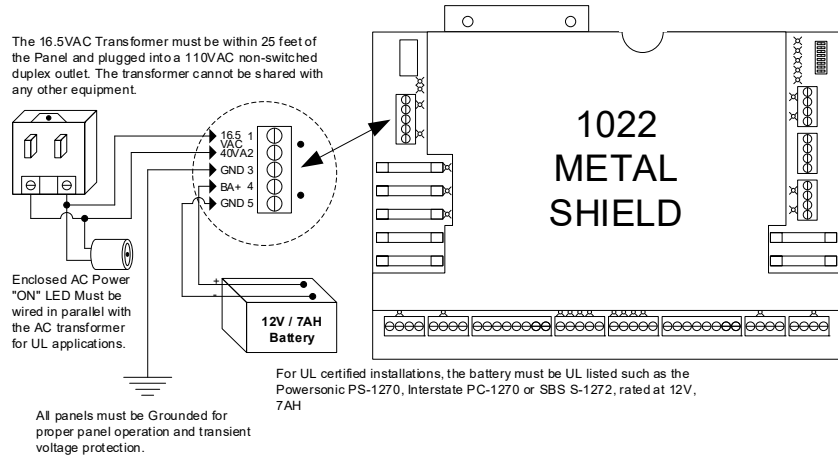

Battery Requirements

All DSX Controllers must have one Back-up Battery. The Battery must be a Powersonic PS-1270, an Interstate PC-1270, or an SBS S-1272. Other batteries may draw too much current on initial recharge.

Battery Positive

This output provides the connection to the on-board Battery charging circuit. This charging circuit can maintain one 12V 7AH battery. Battery Connections are made on terminal 4 for battery positive.

Battery Negative

This is the connection for the negative side of the 12V 7AH battery. It is electrically the same as the Earth Ground Terminal as are all negative terminals on the controller. Terminal 5 is the negative battery connection.

Low Battery Supervision

If low voltage is detected, an LED is illuminated on the controller and a report is sent to the PC. DSX-1022 controllers routinely load test the battery to ensure battery integrity. This test is automatically performed each day at 10:00 AM. At 10:00AM, the charging circuit is disengaged and a 1A load is put on the battery. At 10:01AM, the load is removed, and the charging circuit is reapplied to the battery. During this one-minute interval, if the battery voltage drops below 11.5 volts or if there is no battery, the Low Battery LED will be illuminated, and a Low Battery report will be sent to the PC.

Standby Time

Standby time will vary depending on the condition of the battery and the amount of load connected to the external voltage outputs of the DSX controller.

Standby time on a DSX-1022 with maximum load is 3.3 hours.

Current draw on an unloaded DSX-1022 is 540ma.

Ground Connections

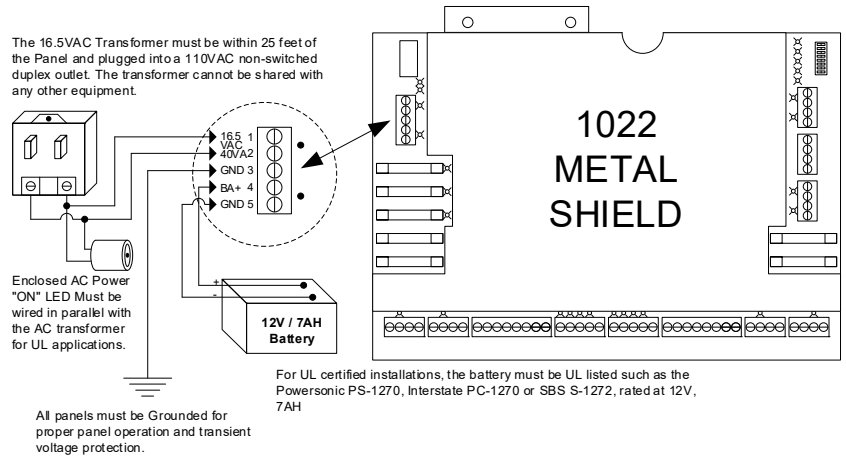

Earth Ground

This is where the Earth Ground Wire must be connected on all controllers. Grounding is imperative for proper data communications between controllers and to ensure full functionality of the lightning and transient voltage protection devices. Voltage protection devices are designed into all DSX controllers and will channel most transient surges to ground if the controller is connected to ground. If the controllers are not properly grounded, the surge suppression devices may not function, and data communications may be erratic.

Recommended Grounding Sources

- Sources are listed in order of best functionality:
- Cold Water Earth Ground
 - Building Ground
 - Electrical Ground

Wire Recommendations

The Earth Ground Wire for all DSX controllers should be a 16 AWG wires with the shortest wire run possible.

Multi-Controller Configurations

When connecting Ground to each controller in a multi-controller application be sure there is an individual connection from each controller to ground. This includes applications where several controllers are located next to each other in a group. The ground wire should not loop from controller to controller but rather should home run to each one from the ground source.

Diagnostic and Trouble LEDs

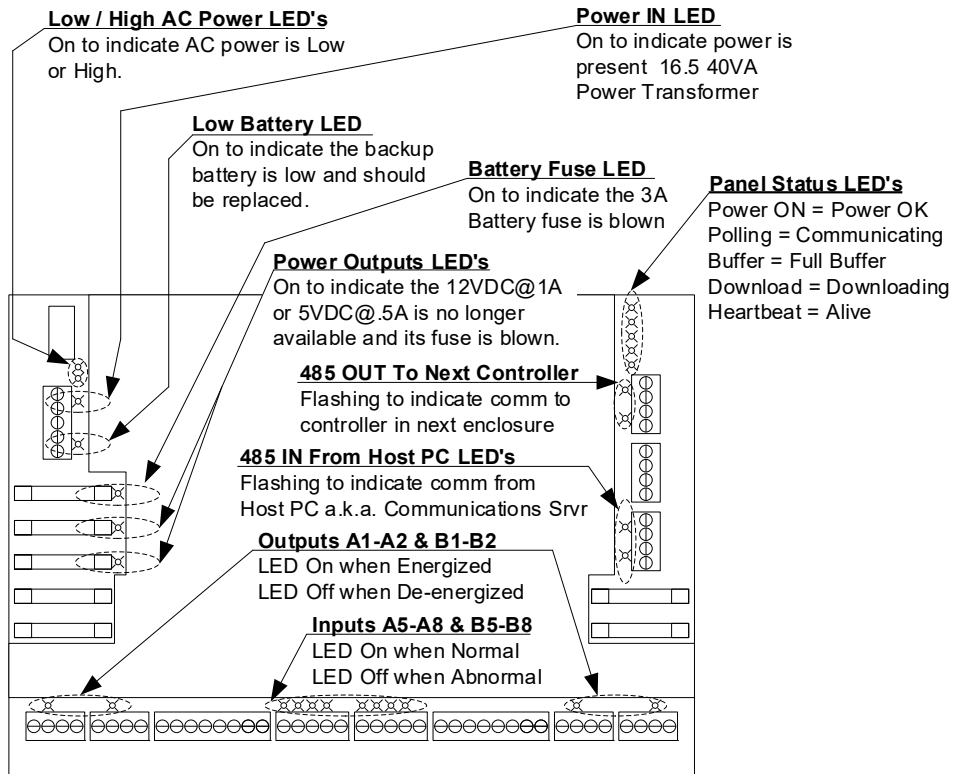

1022 Intelligent Controller

Power Status LEDs

High AC LED

This LED illuminates when the AC input reaches 20VAC or more. When the AC input voltage becomes too high, the LED will turn on and a report is be sent to the PC if the condition maintains for 30 seconds or more.

Low AC LED

This LED illuminates when the AC input reaches 15VAC or less. When the AC voltage becomes too low, the LED will turn on and a report is sent to the PC if the condition maintains for 30 seconds or more.

Low Battery LED

This LED illuminates when the Battery Voltage reaches 11.5VDC or less. When the Battery voltage becomes too low, the LED will turn on and a report is sent to the PC if the condition maintains for 30 seconds or more.

Fuse Ratings and Locations

If one of the Blown Fuse LEDs are illuminated or there is no voltage present on one of the DC output terminals of the I/O board, follow these instructions and use the replacement fuses specified below.

To Replace a Fuse

1. Unplug all terminal blocks on the controller. Remove AC Power first, then remove the Battery connection.
2. Locate fuses according to the diagrams lower on this page and replace the blown fuse.
3. Determine the reason for the blown fuse and correct the problem.
4. To remove the blown fuse, pry up on the end of the fuse farthest from the controller.
5. Reassemble the unit and reconnect the terminal blocks.

Recommended Replacement Fuses

Fuse Name	Littelfuse Part #	Fuse Rating	DSX-1022 Fuse #
12VDC Fuse	312001	250V 1amp	F1
5VDC Fuse	312.500	250V .5amp	F2
Battery Fuse	312003	250V 3amp	F3
Output Relays	312001	250V 1amp	F4-F7

Fuse Locations

F4 thru F7 = Output Relay / Littelfuse Part #312001 / 250V 1amp
 F1 = AUX 12VDC Output / Littelfuse Part #312001 / 250V 1amp
 F2 = AUX 5VDC Output / Littelfuse Part #312.500 / 250V .5amp
 F3 = Battery / Littelfuse Part #312003 / 250V 3amp

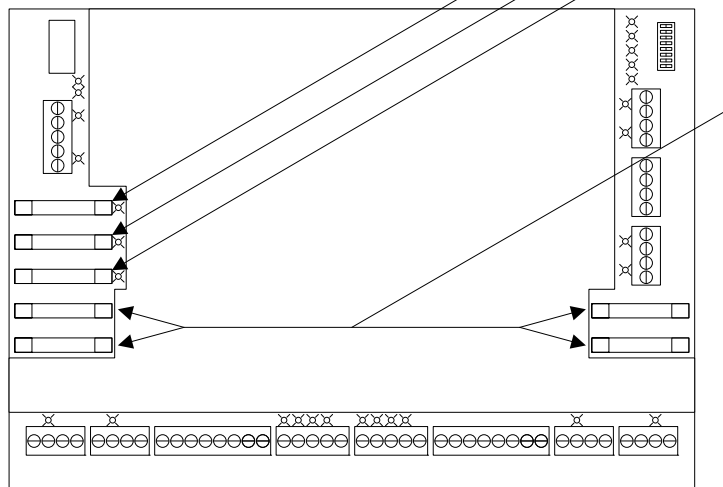

1022 Intelligent Controller

Cable Specifications

All DSX-1022 system wiring must be done in compliance with the National Electrical Code, ANSI / NFPA 70 regulations, and recommendations for U.S. Installations. Canadian Installations must be done in accordance with the Canadian Electric Code C22.1 and require a minimum of 18 Ga. wire for all cables used. The wiring part numbers listed are for example only; use these to cross reference to another manufacturer if needed.

RS-485

RS-485 is used for panel-to-panel communications for all DSX Controllers. RS-485 is also an optional method of communications for the Host PC to Master panel that can extend the wire distance to 4,000 feet. The DSX-1022 and 1020 controllers include only an RS-485 method of communications for the Host PC to the Master panel therefore a DSX-MCI module is required to connect a DSX-1022 and 1020 Master controller to the Host PC. All RS-485 communications require two twisted pair and can have a maximum distance of 4,000 feet.

The recommended cable is:

PVC - Belden 9744 - 22 AWG 2 twisted pair, 4,000 feet max.

Plenum - Belden 82741 - 22 AWG 2 twisted pair, 4,000 feet max.

Readers and Wiegand Keypads

Card readers and DS-400 Keypads require a 3 pair 22 or 20 AWG cable with an overall braided shield. Maximum distance from the DSX controller to the reader is 250 feet with 22 AWG wire and 500 feet with 20 AWG wire. 3 Pair cable provides: 1 pair for power, 1 pair for Data, and 1 pair for two separate LED control lines. Indala Readers with optional buzzer require 7 conductors. If there is any question on how many conductors are required for a particular reader or keypad, reference the wiring diagram for that reader in this manual. If greater distances are required, the DSX-220 Module will provide up to 1,500 feet for Wiegand or Clock and Data type outputs with 18 AWG wire.

The recommended cable is:

PVC - Belden 9942 or 8777 - 22 AWG 3 pair shielded, 250 feet max.

Plenum - Belden 82777 - 22 AWG 3 pair shielded, 250 feet max.

PVC - Belden 9873 - 20 AWG 3 pair shielded, 500 feet max.

Plenum - Belden 83606 or 85164 - 20 AWG 3 pair shielded, 500 feet max.

Note /// All 5Volt powered Readers and Keypads that draw 50ma or more should have a minimum of an 18 AWG cable.

Locks

12-24 Volt Lock wire from door to controller. All locks require a 16 AWG 2 conductor cable and have a maximum distance of 500 feet.

The recommended cable is:

PVC - Belden 8471 - 16 AWG 1 pair, 500 feet max.

Plenum - Belden 1862A - 16 AWG 1 pair, 500 feet max.

PVC - Belden 8461 - 18 AWG 1 pair, 250 feet max.

Plenum - Belden 82740 - 18 AWG 1 pair, 250 feet max.

Inputs

Input wire from monitored device to controller. All inputs require a 22 AWG 2 conductor cable and have a maximum distance of up to 1,000 feet. (Shielded cable is required for UL installations.)

The recommended cable is:

PVC - Belden 8451 - 22 AWG 1 pair, 1,000 feet max.

Plenum - Belden 82761 - 22 AWG 1 pair, 1,000 feet max.

AC Transformer

AC power wire from transformer to controller. Primary AC power to the controller from the transformer requires an 18 AWG 1 pair cable with a maximum distance of 25 feet.

The recommended cable is:

PVC - Belden 8461 - 18 AWG 1 pair, 25 feet max.

Plenum - Belden 82740 - 18 AWG 1 pair, 25 feet max.

Elevator Cable

Elevator Travel Cable for Card Readers requires a 20 AWG 3 Pair stranded elevator travel cable with an overall foil braided shield. It is very important that the cable is designed for use as an elevator travel cable. Normal stranded cable cannot withstand the constant flexing caused by the elevator movement.

The recommended cable is:

BIW - 626PR04-00S - 20 AWG 4 pair, 500 feet max. Stranded Steel Center Core

It may be necessary to contract the additional cable to be installed by a certified elevator company. If using pairs of wires in existing travel cables, the outer pairs of the cable in reference to the inner core are preferable. Under harsh conditions, induced voltages or signals may prevent the readers in an elevator or other application from working. This can possibly be overcome with the use of the DSX-220 Module.

LAN

LAN cable is used for PC-to-PC communications. Ethernet Coax has a maximum distance of 600 feet. 10Base T has a maximum distance of 300 feet per run. The type of LAN and configuration dictates the topology and wire to be used.

The recommended cable is:

PVC - Belden 1583A- 24 AWG 4 pair, 10Base T, 300 feet max.

Plenum - Belden 1585A- 24 AWG 4 pair, 10BaseT, 300 feet max.

UL Installation Requirements

Controller Tamper

Connect the provided Sentrol 3012 Tamper Switch to an available input on the DSX Controller. The 1K-ohm E.O.L. Resistor should be in series with one of the leads of the tamper switch on the DSX-1022. Program this input to be on a 24hr Time Zone so that it will be always armed. Give the input a name as to properly describe it, such as "Device ## Controller Door Tamper"

External Power-On Indicator

The external power-on LED must be installed in the hole marked "AC Power On" on the side of the enclosure. Run the wires through the hole from the outside to the inside of the enclosure and connect them, to terminals 1 and 2 of the DSX-1022 along with AC input wires from the transformer. The LED housing has a locking nut that will hold it into place.

Transformer

For UL 294 and CSA C22.2 No. 205 installations, the DSX-1022 Intelligent Controller is only intended for use with a UL Listed (EPBU, EPBU7) Class 2 transformer like the one manufactured by Revere Industries, Cat. No. RT-1640SL/M. Input rated 120 VAC, 60 Hz, 49 VA; output rated 16.5 VAC, 40 VA, 60 Hz. **To meet the additional requirements of UL 1076 a DSX-1022 must be powered with 2 - 16.5VAC, 40VA transformers wired in parallel. They must be of the same make, model and distance from Controller. The two transformers must both have a separate but similar cable from the transformer to the controller where they are wired in parallel.**

Battery

A back-up battery must be used with every DSX controller installed. DSX recommends the Powersonic PS-1270, the Interstate PC-1270 and the SBS S-1272.

DSX-1022 Standby time is 3.3 hours, per 7ah battery, with maximum load.

To meet the additional requirements of UL 1076 a DSX-1022 must have 2- 12V, 7ah batteries. The two batteries should be connected in parallel.

Readers

UL Installations require all readers used to be UL Listed.

Exhaust Fan

The exhaust fan mounts in the upper left of the DSX-1022E enclosure and should push air out of the enclosure. Terminate the fan on the 1022 Reader Port 12v and ground terminals.

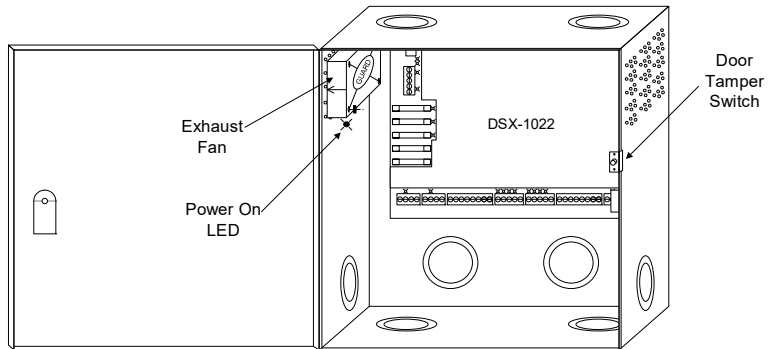

Outputs

Lock Outputs can be programmed for Fail Safe and/or Fail Secure determined by the local authority having jurisdiction.

Locks

All Locks must be UL Listed.

Pre-Warn Outputs

Pre-Warn outputs can be used for UL 294 Installations.

Communications

Telco / Modem communications cannot be used for UL Installations.

Inputs

Door Open Too Long time should not exceed 60 seconds. Abort Delay Times should not exceed 60 seconds on entry exit doors.

Access Control Performance Levels

Ratings	Score
Line Security	I
Attack Test	I
Standby Power	I
Endurance	IV

DSX-1022 Controller Addressing

Master/Sub Dip Switch Settings

The controller mode is selected by switch 8 of the 8-position dipswitch assembly. The controller mode determines if the controller will be a Master or Sub. The Master automatically detects a modem or direct connection and communicates appropriately. There is only one Master controller per location. The Master controller polls the Sub controllers and reports information to and from the PC. The Master Controller is always defined as devices 0&1.

The 1022 dipswitches are used to:

- ❑ Switch 8 defines controller as a Master unit or Sub unit.
- ❑ Switches 1-7 define the Location address for the Master controller or Device address for the Sub controller.

Switch Definitions

Switch #	Switch Value	
1	1	used on Master only
2	2	
3	4	
4	8	
5	16	
6	32	
7	64	For addresses greater than 127 set switches 1-7 off and use KB2CW.exe to set the location address.
8	>	On for Master / Off for Sub

Location Address (Master)

When a controller is configured as a Master (switch 8 On), the address switches determine the Location Number. Valid location addresses are 1 through 32,000. The Master controller, which is also used as a Sub, has a device address automatically set to 0 and 1. The device address is automatically 0 and 1 because the address switches on the Master must be used to designate the location number. For addresses greater than 127 set switches 1-7 off and use KB2CW.exe located in the WinDSX directory to set the location address.

Device Address (Sub)

When a controller is configured as a Sub, the address switches determine the device address of the controller. Valid device addresses are 0 through 126. Each DSX Sub controller represents 2 devices and therefore uses 2 consecutive device addresses. Each controller is 2 separate devices. The controllers are divided down the middle, with all terminals on the left (Side A) dedicated to the even device address and all terminals on the right (Side B) dedicated to the odd device address. The even number address is programmed in the dipswitches, the odd is automatically assumed. Therefore, valid device address settings are 0, 2, 4, 6...62. A DSX-1022 with a device address setting of 10 would represent addresses 10 and 11. The inputs and outputs on side A of the DSX-1022 would respond as device 10 and the inputs and outputs on side B would respond as device 11.

Typical Address Settings for DSX System

Example

The drawing below is an example of a single PC, direct connect, 4 panel / 8 device system. This is a most common application. This example shows the Location 1 Master panel directly connected to the PC's Comm Port 1 with several Sub controllers connected to the Master. The example shows the Location 1 Master Controller addressed with switches 1 and 8 ON. If a system included other Locations, the Master Controller for those Locations would not have only switch 1 ON but may have switches 2 and 8 ON for Location 2's Master or 1&2&8 ON for Location 3's Master or 3&8 ON for Location 4's Master etc. For location addresses greater than 127, set switches 1-7 off and use KB2CW.exe, "LO" command, to set the location address.

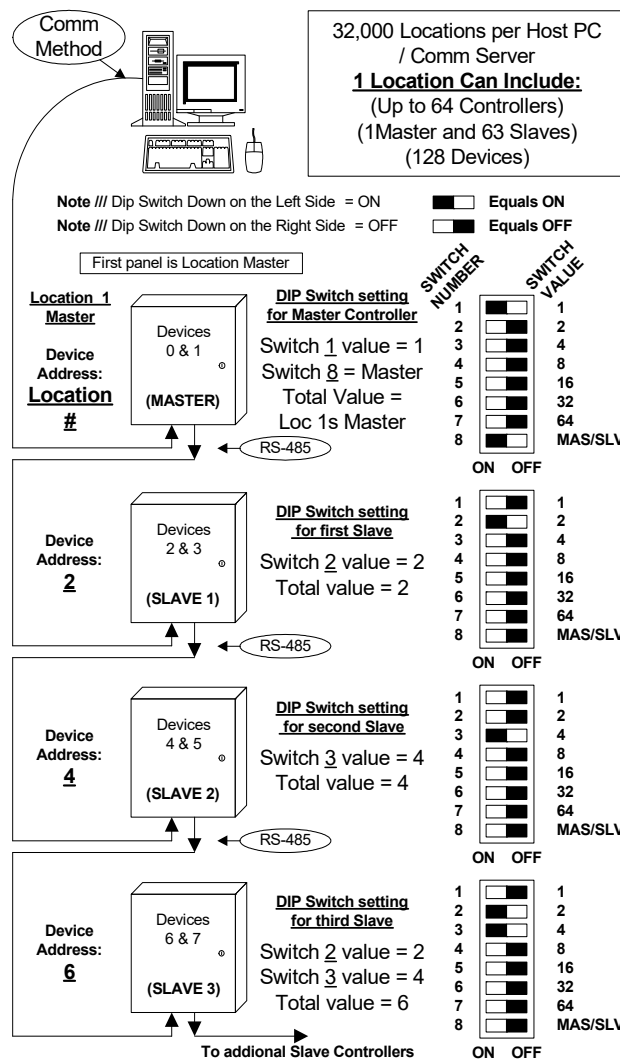

Note /// Dip Switch at a Master panel must equal the Location #.
 Note /// Dip Switch at a Slave panel must equal Device Address of Side A.

Note /// Remember to power the controller down for at least 5 seconds after changing any of the address dipswitches on the DSX-1022 Controller.

Chart of Address Settings 0-63 (uses switches 1-6 only)

The darker block is the side of the switch that is pressed down.

The chart displays 64 individual switch configurations, each labeled with an address number from #0 to #63. Each configuration consists of six switches, numbered 1 through 6. Each switch has two positions: 'On' (indicated by a dark grey block) and 'Off' (indicated by a light grey block). The configurations are arranged in a grid, with addresses #0 & #64 at the top left and #63 at the bottom right. A legend at the bottom of the chart provides a key for the switch states and includes a diagram of a physical switch with four positions labeled 1, 2, 3, and 4, corresponding to the legend's definitions: 1 = On, 2 = On, 3 = Off, 4 = Off.

Master/Sub Address

The Master Address can be any of the address numbers shown on this page. The Sub Device Address will always be an even number. Since each DSX intelligent control controller represents two devices. The left side (side A) is the even number device set by the switch and the right side (side B) is automatically assigned the next highest odd numbered.

Chart of Address Settings 64-127 (uses switches 1-7)

The darker block is the side of the switch that is pressed down.

#64	#65	#66	#67	#68	#69	#70	#71
#72	#73	#74	#75	#76	#77	#78	#79
#80	#81	#82	#83	#84	#85	#86	#87
#88	#89	#90	#91	#92	#93	#94	#95
#96	#97	#98	#99	#100	#101	#102	#103
#104	#105	#106	#107	#108	#109	#110	#111
#112	#113	#114	#115	#116	#117	#118	#119
#120	#121	#122	#123	#124	#125	#126	#127

On Off	On Off	On Off	On Off	On Off
	= Off	= On		

On Off	On Off	On Off	On Off

	1	1 = On
	2	2 = On
	3	3 = Off
	4	4 = Off

Master/Sub Address 64 – 127

The value of switch number 7 is 64. Turn switch 7 On for a base address of 64, adding to it the value of any other switch that is turned On. For example, Switch 1, 7, and 8 On would be the Master Controller for Location 65. Switches 1 and 8 would not be used for a Sub Controller. For example, Switch 2 and 7 On would be a Sub Controller with a device address of 66 on Side A and 67 on Side B.

Note /// To address the Master Controller higher than 127 set switches 1-7 off and use KB2CW.exe to set the Location address. KB2CW.exe can be found in the WinDSX directory.

Note /// To change the dip switch setting, power the controller down, change the address dip switch setting of the controller then power up the controller.

Inputs

The DSX-1022 controller provides 8 EOL supervised inputs. All these inputs can be used for general status or point monitoring and exit request. The DSX controller consumes 2 system device addresses (as seen by the PC). The inputs on Side A (left side) are the inputs for the even numbered device. The inputs on side B (right side) are the inputs for the odd numbered device.

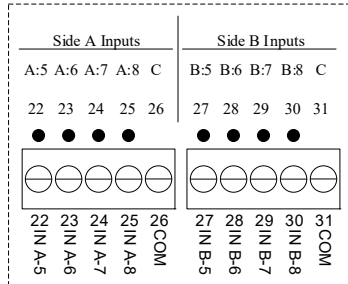

1022 Inputs

Input Characteristics

The inputs on the DSX-1022 are supervised using a 1K-ohm end of line resistor. All inputs may be wired normally open or normally closed. Maximum loop resistance is plus or minus 100 ohms.

- ❑ Input voltage at 6.0 volts = circuit is normal.
- ❑ Input voltage at 0.0 volts = circuit is shorted.
- ❑ Input voltage at 12.0 volts = circuit is open.

Input Status LED's.

There is a separate LED indicator for each input on the DSX-1022. The LEDs are On when the input is normal and Off when the input is abnormal. The LED indicators will always follow the input's true electrical state regardless of how the input is programmed. The true state of an input is always reflected by the LED and always shown from the Workstation program of WinDSX even when the input is shunted.

Standard Inputs

All Inputs excluding Inputs 7-8 on any DSX Controller are normally configured as general-purpose inputs to monitor anything with a dry contact output.

Input 7 Door Position Input

Input 7 is automatically reserved as the door position switch for an access-controlled door. Input 7 is also automatically defined when you add a Device. This newly added Input 7 is named the same as the Device. All shunting for valid entries or exits takes place automatically. The DSX panel performs an internal software link, which will automatically bypass the input any time the door control output (output 1) is OPEN. The input can be programmed as a general-purpose input by answering the question *Use Input 7 & 8* with a No when defining the Device parameters in the Database program. If the door is opened following a valid card read or exit request and shut before the Door Held Open Time expires, no alarm is generated. If programmed, the door will relock automatically when it is opened. Door Open too Long Time cannot exceed 60 seconds.

Note /// See connection graphics in the next few pages for Inputs 7 & 8 and Output 1 on 1022.

Input 8 Exit Request

Input 8 is automatically reserved as the exit request input when a keypad or card reader is attached to the DSX-1022. If side A is controlling a door, then side A input 8 is used for the exit button or egress motion detector. The same applies to side B input 8. The exit request linking takes place automatically and requires no special programming. The input can be programmed as a general-purpose input by setting the field *Use Input 7 & 8* to a No or by removing its check mark when defining the Device parameters in the Database program. If Input 8 is abnormal, relay 1 on the same side of the panel is Open or De-energized. For this reason, Input 8 should be programmed with a 24hr time zone and given an Abort Delay Time of 60 seconds. Configured this way, if input 8 becomes abnormal and stays abnormal for too long, an alarm will be reported to the PC indicating that the door is unlocked. If Input 8 is not used, it should be terminated with a 1K-ohm resistor as should all unused, supervised, input points.

Input 8 can be programmed to not unlock the door upon activation, but rather initiate all shunts and door timing. To do this Answer the question *Exit Request Unlocks Output 1* with a No or by removing its check mark when defining the Device parameters in the Database program. This is typically done with doors that use free egress such as doors that use strikes or have crash bars and a motion detector for egress. In timing critical situations, it may be necessary to program input 8 with no Time Zone and no Abort Delay Time. When the Device is programmed for the request to exit input not to unlock the door do not assign a time zone to input 8.

Abort Delay Time

Abort Delay Time describes the amount of time an armed input must remain abnormal before an alarm is transmitted to the PC. If a door being monitored by the system has an abort delay time of 10 seconds and the door is opened and then closed within a 7-second time frame, no alarm would be generated. But if it were opened for 11 seconds, an alarm would be sent to the PC. This would be transmitted as an alarm displaying the input name, not as a Door Held Open alarm. For UL installations do not exceed 60 seconds.

If Abort Delay Times are programmed for door contacts connected to input 7, the abort delay time will only affect the amount of time required to activate a door forced open report from the input. It does not add on to the door held open time or affect any other timed functions in any way.

It is recommended that input 8 is armed and given an abort delay time in most cases. If the egress input 8 is connected to a motion detector and is programmed not to unlock the door, and does not have much range from the door, it may be necessary to program the Input 8 with no time zone and no abort delay time.

Panel Tamper

Connect the provided Sentrol 3012 tamper switch to an available input on the DSX controller. The 1K EOL resistor should be in series with one of the wire leads from the tamper switch to an input on the DSX Controller. There is no 1K EOL needed for the DSX-1043 inputs. Program this input with the name Panel Door Tamper. Program the input to be on a 24hr time zone, so that it is always armed.

Note /// All Unused, supervised Inputs on any DSX Controller should be terminated with a 1K EOL Resistor! The EOL Resistors that are shipped with each DSX controller should be 1K ohm. If you are experiencing input problems with a new installation verify the resistor value with an ohmmeter.

Two, Three, and Four State Input Monitoring

Systems using WinDSX Software support two, three, and four state supervised input monitoring. There are five programmable circuit types, which are shown below. Two and three state inputs use a 1K-ohm resistor. Four state inputs utilize a 180-ohm and 820-ohm resistor each. All inputs can be individually programmed for any one of the five circuit types. Three and Four State inputs support trouble conditions.

- Input Circuit Types: 0 = 2 States, Type 1 & 2 = 3 States, Type 3 & 4 = 4 States.
- These Input Circuit Types apply to all Controllers except the DSX-1043 and DSX-1033.
- When armed, all input types generate an alarm in addition to the applicable trouble indication when in an open or shorted condition.

Input Circuit Type 0

Reports **2 states** of the circuit. If the circuit changes by 100 Ohms an alarm is sent to the PC.

- 1) This circuit is normal at 1000 Ohms.
- 2) This circuit alarms at + or - @ 100 Ohms.

Normally Open & or Normally Closed Sensors
 Circuit Normal at 1000 Ohms = State 1
 Sensor (NO) Closes = Alarm = State 2
 Sensor (NC) Opens = Alarm = State 2

State 1 = 1000 Ohms = Normal
 State 2 = More than 1100 Ohms = Alarm
 State 2 = Less than 900 Ohms = Alarm

Input Circuit Type 1

Reports **3 states** of the circuit.

- 1) This circuit is normal at 1000 Ohms.
- 2) This circuit will show trouble if the circuit shorts.
- 3) This circuit alarms if the (NC) sensor opens.

Normally Closed Sensors
 Circuit Normal at 1000 Ohms = State 1
 Circuit Shorts = Trouble = State 2
 Sensor (NC) Opens = Alarm = State 3

State 1 = 1000 Ohms = Normal
 State 2 = Short = Trouble
 State 3 = Open = Alarm

Input Circuit Type 2

Reports **3 states** of the circuit.

- 1) This circuit is normal at 1000 Ohms.
- 2) This circuit will show trouble if the circuit opens.
- 3) This circuit alarms if the (NO) sensor closes.

Normally Open Sensors
 Circuit Normal at 1000 Ohms = State 1
 Circuit Opens = Trouble = State 2
 Sensor (NO) Closes = Alarm = State 3

State 1 = 1000 Ohms = Normal
 State 2 = Open = Trouble
 State 3 = Short = Alarm

Input Circuit Type 3

Reports **4 states** of the circuit.

- 1) This circuit is normal at 820 Ohms.
- 2) This circuit will show trouble if the circuit shorts.
- 3) This circuit will show trouble if the circuit opens.
- 4) This circuit alarms if the (NC) sensor opens.

Normally Closed Sensors
 Circuit Normal at 820 Ohms = State 1
 Circuit Shorts = Trouble = State 2
 Circuit Opens = Trouble = State 3
 Sensor (NC) Opens = Alarm = State 4

State 1 = 820 Ohms = Normal
 State 2 = Short = Trouble
 State 3 = Open = Trouble
 State 4 = 1000 Ohms = Alarm

Input Circuit Type 4

Reports **4 states** of the circuit.

- 1) This circuit is normal at 1000 Ohms.
- 2) This circuit will show trouble if the circuit shorts.
- 3) This circuit will show trouble if the circuit opens.
- 4) This circuit alarms if the (NO) sensor closes.

Normally Open Sensors
 Circuit Normal at 1000 Ohms = State 1
 Circuit Shorts = Trouble = State 2
 Circuit Opens = Trouble = State 3
 Sensor (NO) Closes = Alarm = State 4

State 1 = 1000 Ohms = Normal
 State 2 = Short = Trouble
 State 3 = Open = Trouble
 State 4 = 820 Ohms = Alarm

Door Lock and Input Timing

The following diagram shows the shunt timing involved in a normal exit request at a card or keypad-controlled door. All the linking and shunting between the inputs and the outputs is automatically programmed when a device is defined with a card reader or keypad device type.

In the following example, the device has an unlock time of 3 seconds. Notice that the output is unlocked for a total of 5 seconds even though the *Unlock Time* is set to 3 seconds. An alarm is not generated because the unlock timer does not start until the exit request input is returned to normal. Thus, if the exit button input is abnormal, output 1 will be open and input 7 will be shunted.

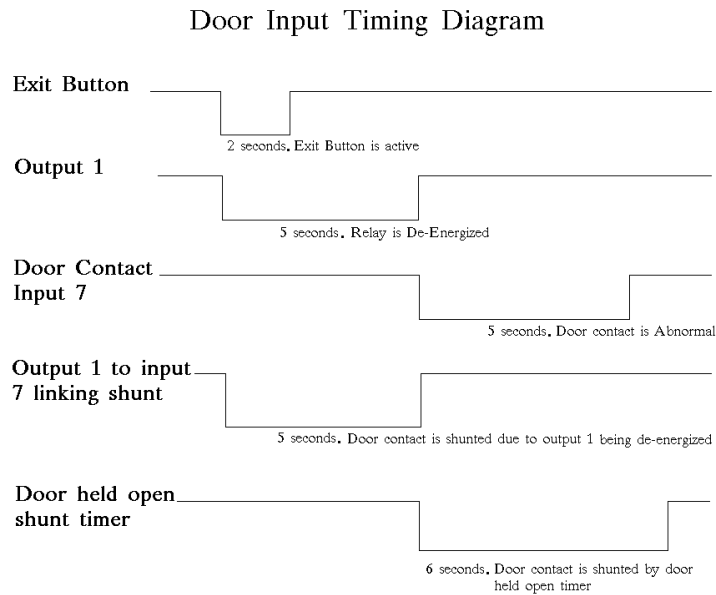

A second example using the previous diagram will establish an unlock time of 10 seconds and door held open time of 30 seconds. The first two seconds are due to the exit request input 8 being abnormal. The next 3 seconds are parts of the 10 second unlock time. As you can see, the output is returned to the secure position before the 10 second unlock time is complete. This occurs due to input 7 changing to an abnormal state. As soon as the door is opened, the lock is returned to its secured state to assure that the door is locked as it is closed. Answering the question *Door Open Detect Relock* with a No, or no checkmark, under Device in the Database program may disable this feature.

Input 7 is shunted in two ways. The first is output 1. Anytime output 1 is OPEN, input 7 is automatically shunted. When output 1 returns to a SECURE state (due to the door opening), the shunt is lifted, the door held open timer starts. When the door contact is returned to normal, the door held open timer will automatically release its shunt 1 second after the door contact is restored. If the door is held open past the time set for the door held open timer, a door held open alarm is transmitted to the PC.

Note /// See connection graphics in the next few pages for Inputs 7 & 8 and Output 1 on 1022.

Outputs

Each DSX-1022 has 2 Relay Outputs. Relay outputs are how the DSX system controls locks, gates, elevators, etc. All relay outputs on any DSX panel are single pole double throw Form C with contacts rated at **5Amps @ 30VDC or 30VAC**. Each Relay Output includes a 1-amp fuse in line with the common terminal of the relay.

Output Status LEDs

Each relay output on a DSX panel has an LED to indicate status. When the LED is Off the output relay is de-energized. When the LED is On the output relay is energized. With the panels default program settings, the door is considered to be Secure when the output relay is Energized (LED On), and Open when the output relay is De-energized (LED Off).

Open/Secure States

The silkscreen information displayed for each relay output shows the relay in its open and normal (de-energized) state. Fail Safe Locks connect to the normally open side of the output. Fail Secure Locks will connect to the normally closed side of the output. Each relay can be programmed for Fail Safe or Secure under Output Relay in the Database program. The use of Fail Safe or Fail Secure locks is subject to approval by the local authority having jurisdiction.

Surge Suppression

When outputs are used to control door strikes, maglocks or any coil or solenoid driven device, it is very important that a surge suppression MOV be installed at the lock or device. If a coil driven device is connected to the output without an MOV, the panel can erratically open and close its relay outputs when the lock power is disengaged. This is due to a high voltage EMF signal generated by the lock or coil when power is removed. A simple MOV placed in parallel with the lock power at the coil will suppress this EMF signal and prevent it from reaching the panel.

MOV Ratings and Part Numbers

The MOVs that DSX recommends and sells for 12V and 24V locks or other coil driven devices are:

- **12V MOV / P7284-ND (Digi-Key) ERZ-V05D270 (Panasonic)**
- **24V MOV / P7286-ND (Digi-Key) ERZ-V05D390 (Panasonic)**

The DSX-1022 controllers have MOVs built-in across the normally open and common and normally closed and common side of each relay. This does not take the place of MOVs at the lock or coil driven device. These built-in MOVs are to prevent the arc produced when the relay contacts make and break. This is to prolong the life of the relay outputs, not to prevent a surge from the lock. If more than 50 volts is switched through the relay, the MOVs must be removed. Call DSX Technical Support for assistance if necessary.

Note /// See additional connection graphic on next page.

Inputs 7, 8 and Output 1 Wiring Diagram

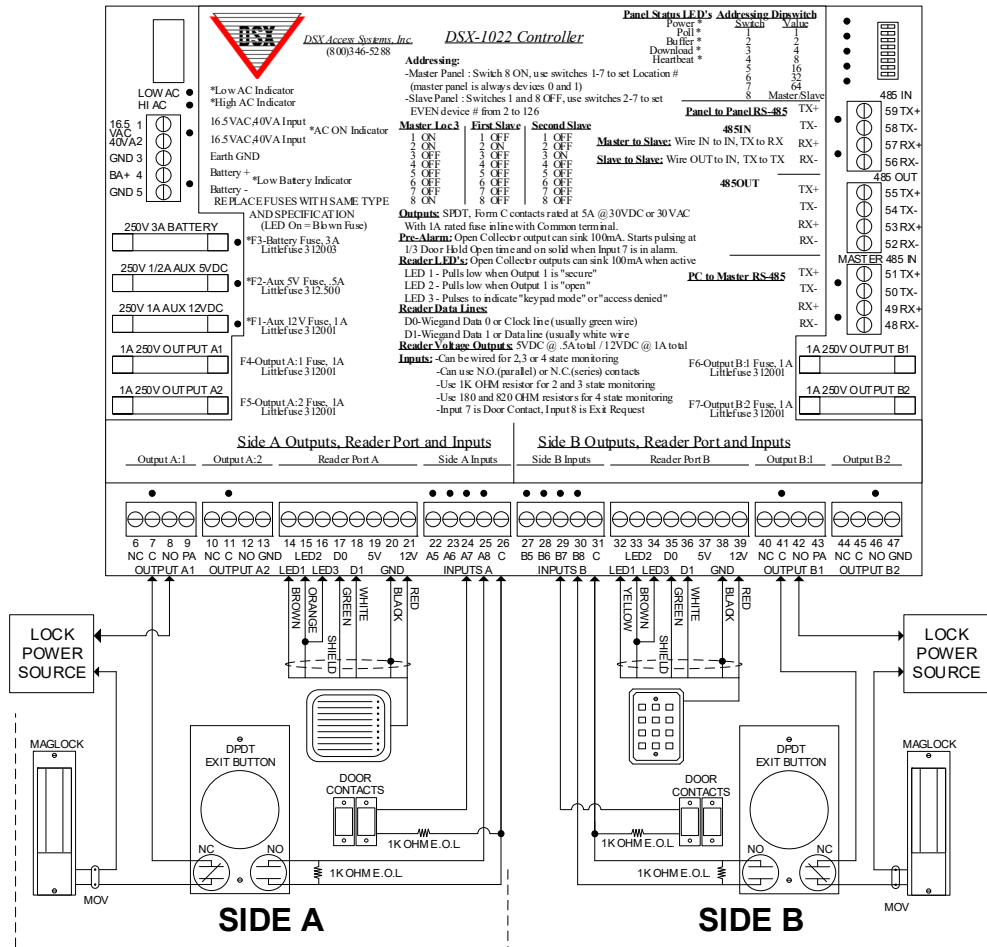

Note /// All coil driven devices require MOVs across the power inputs.

Pre-Alarm Output Operation (a.k.a. Pre-Warn)

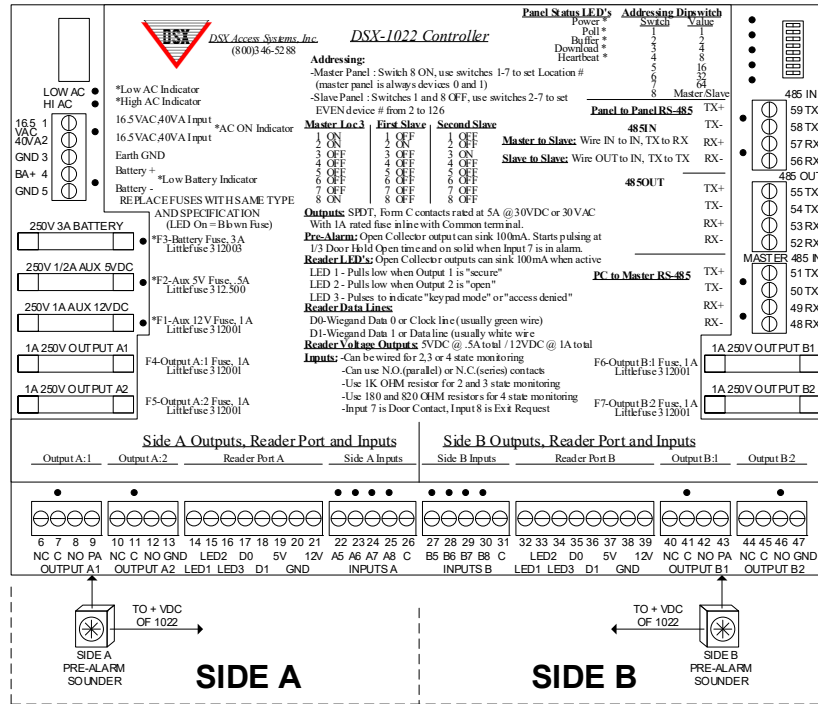

Pre-Alarm connection is an open collector capable of -100mA DC current. Pre-Alarm normally connects to a sounder located near a controlled door to indicate a door has been held open too long.

Pre-Alarm Output Operation (a.k.a. Pre-Warn)

The Pre-Alarm Output becomes active when the door has been open more than 1/3 of the Door Held Open Time and stays active if the door goes into alarm. The output also becomes active when the door is forced open. Once the door is shut, the output automatically turns off. The Pre-Alarm Output is an open collector type (switched negative) that will provide up to -100ma of current.

The Pre-Alarm Output is commonly used to activate a sounder built into the reader. It can also be used to drive a remote sounder or device located near the reader-controlled door. In this situation the pre alarm output is connected to the negative side of the device and the positive side is connected to either the 5 or 12 VDC power from the reader port and the negative would

Note /// The Pre-Alarm output DOES NOT reset because of a card read. The Pre-Alarm output will not activate if Input 7 (of the same Device) is bypassed. The Pre-Alarm output can be used for UL294 Installations.

PC Bound Direct Communications

Direct Connect Master Communications – RS-485

When the Master Controller is a DSX-1022 the PCs RS-232 communications can be converted to RS-485 using a DSX-MCI module at the PC (for Direct Connections) and connect to the Master Controller. RS-485 Communications will support up to 4,000 feet on two twisted pair cable. This application requires one MCI module as shown below.

NOTE \\\ Other communications methods are available. Not all communications methods have been tested by UL.

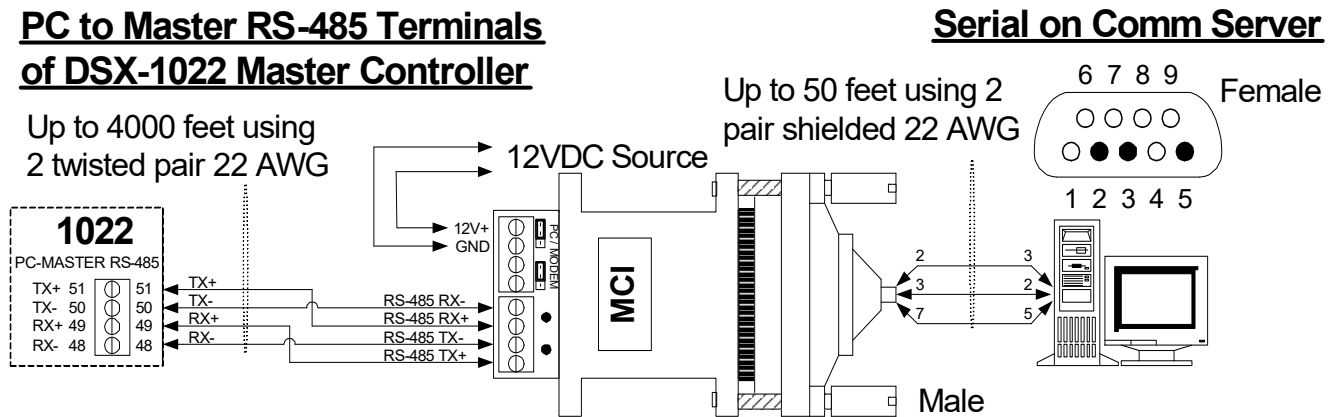
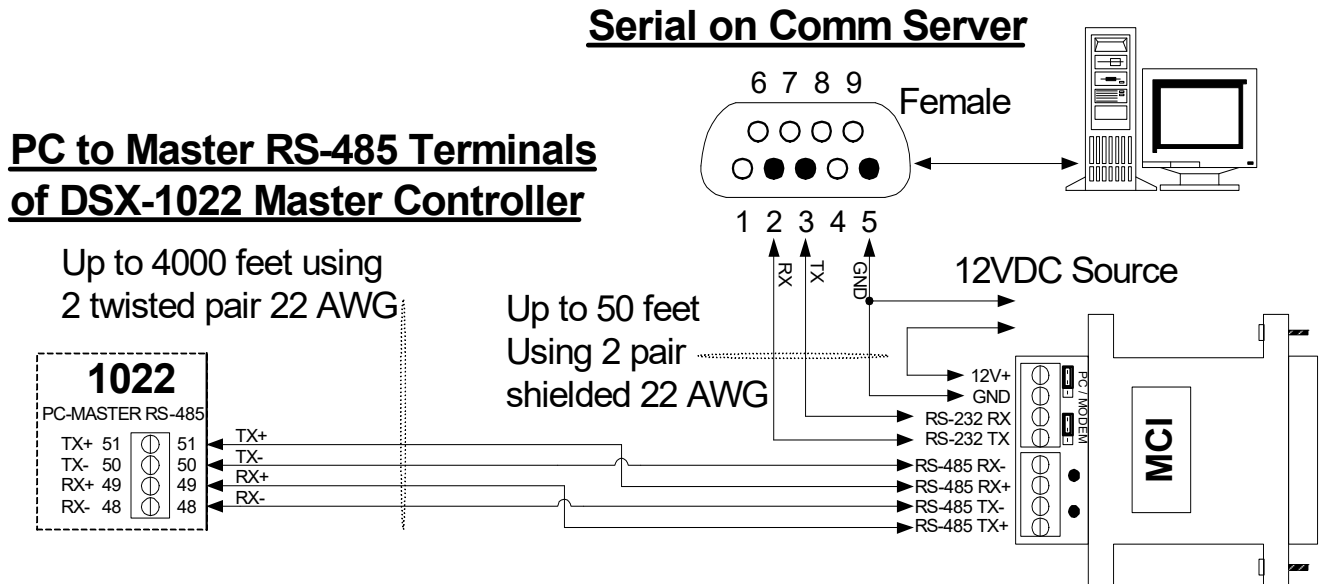

Controller to Controller Communications

Communications Overview

Controller to controller communications utilizes RS-485 between Controller Packages. RS-485 provides a fast and noise immune communications over standard 2 twisted pair wiring. The two twisted pair RS-485 circuit runs from enclosure to enclosure, CDM module to CDM module, in a series loop or daisy chain configuration.

Each DSX-1040CDM module regenerates the RS-485 signal to allow up to 4,000 feet of wire between controller packages. The CDM has two bypass relays that will pass the RS-485 signal through to the next enclosure in case of a failure or power down.

A Star or Branch wiring configuration can be achieved with the use of a DSX-1035 Quadraplexor. The Quadraplexor provides four RS-485 outbound ports and one RS-232 port.

A T-tap wiring configuration can be achieved with the use of a DSX-485T. The DSX-485T provides two RS-485 outbound ports.

Note /// Connection examples for the DSX-1035 and DSX-485T are provided in later sections of this manual.

Communications Overview Block Diagram

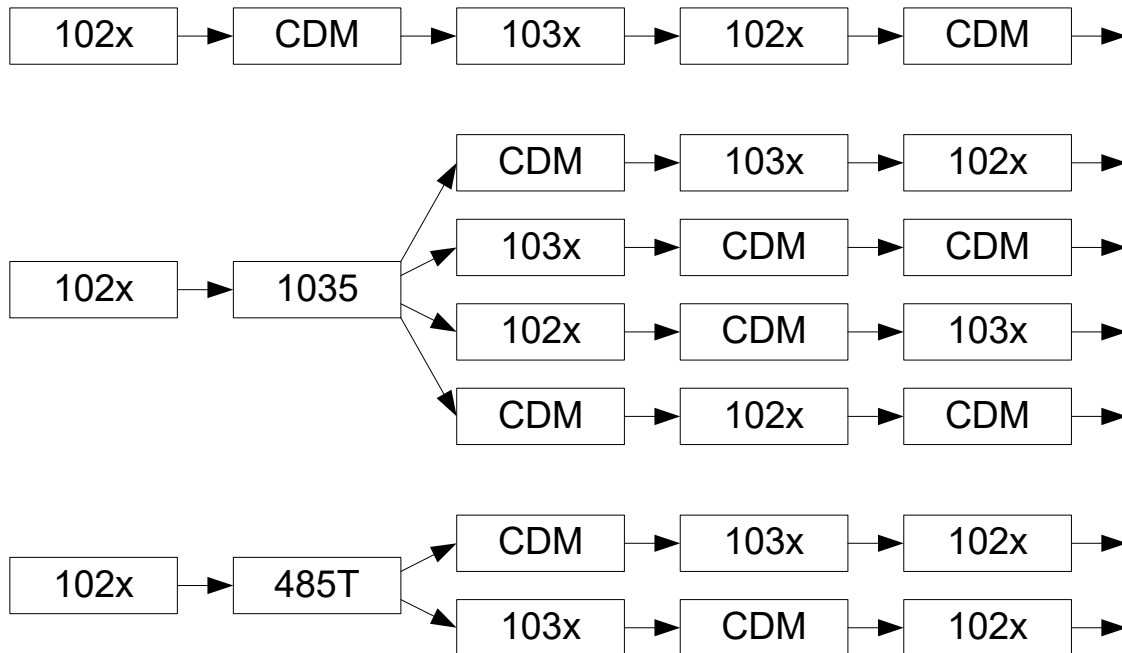

Note /// Any DSX Intelligent Control Panel can connect to any other DSX panel in a Master to Sub or Sub to Sub configuration.

Master to Sub Communications

Use the charts below for terminal-to-terminal wiring information on Master Controller to Sub Controller communication connections. The charts provide wiring information for each generation DSX Controller connecting to every other generation of Controller.

<u>1021 Master To 1021 SUB</u>
485 IN to 485 IN
41, TX+ - 43, RX+
42, TX- - 44, RX-
43, RX+ - 41, TX+
44, RX- - 42, TX-
<u>1021 Master To 1022 SUB</u>
485 IN to 485 IN
41, TX+ - 57, RX+
42, TX- - 56, RX-
43, RX+ - 59, TX+
44, RX- - 58, TX-
<u>1021 Master To 103x SUB</u>
485 IN to 485 IN
41, TX+ - 43, RX+
42, TX- - 44, RX-
43, RX+ - 41, TX+
44, RX- - 42, TX-
<u>1021 Master To 1040CDM w/ SUBs</u>
485 IN to 485 IN
41, TX+ - 7, RX+
42, TX- - 8, RX-
43, RX+ - 5, TX+
44, RX- - 6, TX-

<u>103x Master To 1021 SUB</u>
485 IN to 485 IN
41, TX+ - 43, RX+
42, TX- - 44, RX-
43, RX+ - 41, TX+
44, RX- - 42, TX-
<u>103x Master To 1022 SUB</u>
485 IN to 485 IN
41, TX+ - 57, RX+
42, TX- - 56, RX-
43, RX+ - 59, TX+
44, RX- - 58, TX-
<u>103x Master To 103x SUB</u>
485 IN to 485 IN
41, TX+ - 43, RX+
42, TX- - 44, RX-
43, RX+ - 41, TX+
44, RX- - 42, TX-
<u>103x Master To 1040CDM w/ SUBs</u>
485 IN to 485 IN
41, TX+ - 7, RX+
42, TX- - 8, RX-
43, RX+ - 5, TX+
44, RX- - 6, TX-

<u>1022 Master To 1021 SUB</u>
485 IN to 485 IN
59, TX+ - 43, RX+
58, TX- - 44, RX-
57, RX+ - 41, TX+
56, RX- - 42, TX-
<u>1022 Master To 1022 SUB</u>
485 IN to 485 IN
59, TX+ - 57, RX+
58, TX- - 56, RX-
57, RX+ - 59, TX+
56, RX- - 58, TX-
<u>1022 Master To 103x SUB</u>
485 IN to 485 IN
59, TX+ - 43, RX+
58, TX- - 44, RX-
57, RX+ - 41, TX+
56, RX- - 42, TX-
<u>1022 Master To 1040CDM w/ SUBs</u>
485 IN to 485 IN
59, TX+ - 7, RX+
58, TX- - 8, RX-
57, RX+ - 5, TX+
56, RX- - 6, TX-

<u>1040CDM w/ Master To 1021 SUB</u>
485 IN to 485 IN
5, TX+ - 43, RX+
6, TX- - 44, RX-
7, RX+ - 41, TX+
8, RX- - 42, TX-
<u>1040CDM w/ Master To 1022 SUB</u>
485 IN to 485 IN
5, TX+ - 57, RX+
6, TX- - 56, RX-
7, RX+ - 59, TX+
8, RX- - 58, TX-
<u>1040CDM w/ Master To 103x SUB</u>
485 IN to 485 IN
5, TX+ - 43, RX+
6, TX- - 44, RX-
7, RX+ - 41, TX+
8, RX- - 42, TX-
<u>1040CDM w/ Master To 1040CDM w/ SUB</u>
485 IN to 485 IN
5, TX+ - 7, RX+
6, TX- - 8, RX-
7, RX+ - 5, TX+
8, RX- - 6, TX-

Sub to Sub Communications

Use the charts below for terminal-to-terminal wiring information on Sub Controller to Sub Controller communication connections. The charts provide wiring information for each generation DSX Controller connecting to every other generation of Controller.

<p><u>1021 SUB To 1021 SUB</u></p> <p>485 OUT to 485 IN 45, TX+ - 41, TX+ 46, TX- - 42, TX- 47, RX+ - 43, RX+ 48, RX- - 44, RX-</p> <p><u>1021 SUB To 1022 SUB</u></p> <p>485 OUT to 485 IN 45, TX+ - 59, TX+ 46, TX- - 58, TX- 47, RX+ - 57, RX+ 48, RX- - 56, RX-</p> <p><u>1021 SUB To 103x SUB</u></p> <p>485 OUT to 485 IN 45, TX+ - 41, TX+ 46, TX- - 42, TX- 47, RX+ - 43, RX+ 48, RX- - 44, RX-</p> <p><u>1021 SUB To 1040CDM w/ SUBs</u></p> <p>485 OUT to 485 IN 45, TX+ - 5, TX+ 46, TX- - 6, TX- 47, RX+ - 7, RX+ 48, RX- - 8, RX-</p>
--

<p><u>103x SUB To 1021 SUB</u></p> <p>485 OUT to 485 IN 45, TX+ - 41, TX+ 46, TX- - 42, TX- 47, RX+ - 43, RX+ 48, RX- - 44, RX-</p> <p><u>103x SUB To 1022 SUB</u></p> <p>485 OUT to 485 IN 45, TX+ - 59, TX+ 46, TX- - 58, TX- 47, RX+ - 57, RX+ 48, RX- - 56, RX-</p> <p><u>103x SUB To 103x SUB</u></p> <p>485 OUT to 485 IN 45, TX+ - 41, TX+ 46, TX- - 42, TX- 47, RX+ - 43, RX+ 48, RX- - 44, RX-</p> <p><u>103x SUB To 1040CDM w/ SUBs</u></p> <p>485 OUT to 485 IN 45, TX+ - 5, TX+ 46, TX- - 6, TX- 47, RX+ - 7, RX+ 48, RX- - 8, RX-</p>
--

<p><u>1022 SUB To 1021 SUB</u></p> <p>485 OUT to 485 IN 55, TX+ - 41, TX+ 54, TX- - 42, TX- 53, RX+ - 43, RX+ 52, RX- - 44, RX-</p> <p><u>1022 SUB To 1022 SUB</u></p> <p>485 OUT to 485 IN 55, TX+ - 59, TX+ 54, TX- - 58, TX- 53, RX+ - 57, RX+ 52, RX- - 56, RX-</p> <p><u>1022 SUB To 103x SUB</u></p> <p>485 OUT to 485 IN 55, TX+ - 41, TX+ 54, TX- - 42, TX- 53, RX+ - 43, RX+ 52, RX- - 44, RX-</p> <p><u>1022 SUB To 1040CDM w/ SUBs</u></p> <p>485 OUT to 485 IN 55, TX+ - 5, TX+ 54, TX- - 6, TX- 53, RX+ - 7, RX+ 52, RX- - 8, RX-</p>
--

<p><u>1040CDM w/ SUBs To 1021 SUB</u></p> <p>485 OUT to 485 IN 9, RX+ - 41, TX+ 10, RX- - 42, TX- 11, TX+ - 43, RX+ 12, TX- - 44, RX-</p> <p><u>1040CDM w/ SUBs To 1022 SUB</u></p> <p>485 OUT to 485 IN 9, RX+ - 59, TX+ 10, RX- - 58, TX- 11, TX+ - 57, RX+ 12, TX- - 56, RX-</p> <p><u>1040CDM w/ SUBs To 103x SUB</u></p> <p>485 OUT to 485 IN 9, RX+ - 41, TX+ 10, RX- - 42, TX- 11, TX+ - 43, RX+ 12, TX- - 44, RX-</p> <p><u>1040CDM w/ SUBs To 1040CDM w/ SUBs</u></p> <p>485 OUT to 485 IN 9, RX+ - 5, TX+ 10, RX- - 6, TX- 11, TX+ - 7, RX+ 12, TX- - 8, RX-</p>
--

DSX-1035 Quadraplexor

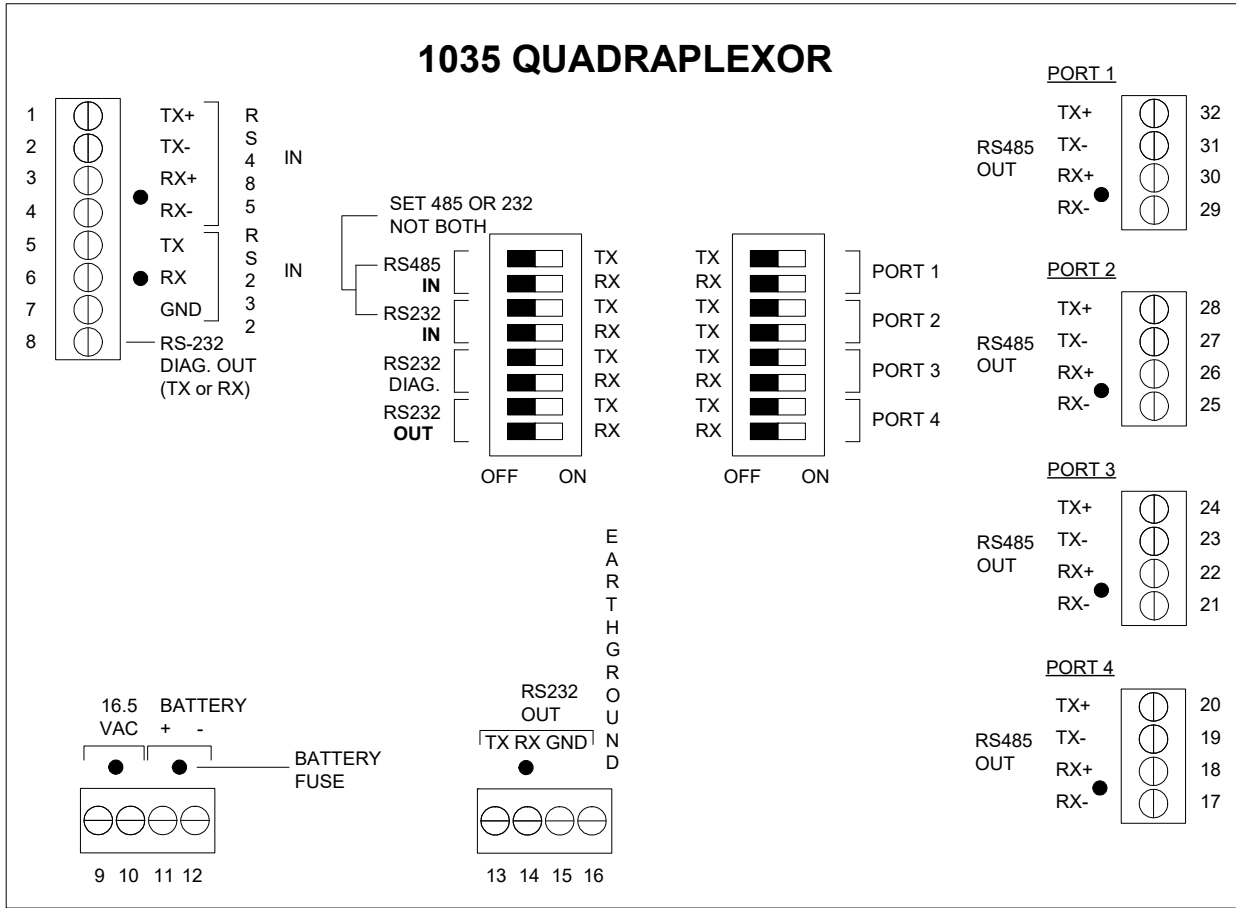

Overview

The DSX-1035 Quadraplexor can be used as a communications multiplexor or a short haul modem. The DSX-1035 accepts RS-232 or RS-485 as input and provides four RS-485 outputs and one RS-232 output simultaneously. The 1035 has the following uses and features.

- Provides multiple DSX Master to DSX Sub RS-485 communications paths at rates up to 9600 baud.
- RS-232 to RS-485 converter.
- RS-232 or RS-485 short haul modem.
- The DSX-1035 Quadraplexor can transmit other data sources at rates up to 57.6K bit over 2 twisted pair wiring for distances up to 4,000 feet.

Grounding

The DSX-1035 must have an Earth Ground Connection for proper communications and for the internal surge protection to work.

Power Requirements and Connections

1035	Terminals
AC=16.5 20VA	9 and 10
Battery 12V	11 and 12
Ground	16

The DSX-1035 Quadraplexor can be powered from a DSX-1022 instead of its own transformer and battery. This can be accomplished by not connecting a transformer to the DSX-1035, but instead, connect the 12 VDC output of the DSX-1022 to the Battery (+) and (-) terminals (11 & 12) of the 1035 Quadraplexor.

Dip Switch Settings

The dipswitches on the DSX-1035 are used to set the input and output ports. The switches enable either RS-232 or RS-485 as the input. They also enable each of the four RS-485 and RS-232 output ports.

The following is a description of each dipswitch and its function. A Port is activated by placing its corresponding TX and RX switch in the on position.

Do Not Enable both the RS-232 and RS-485 inputs of the DSX-1035. Only one input type can be selected at a time.

Right 8 position dip switch	Left 8 position dip switch
1. RS-485 TX IN	1. RS-485 Port 1 TX
2. RS-485 RX IN	2. RS-485 Port 1 RX
3. RS-232 TX IN	3. RS-485 Port 2 TX
4. RS-232 RX IN	4. RS-485 Port 2 RX
5. RS-232 Diag TX OUT	5. RS-485 Port 3 TX
6. RS-232 Diag RX OUT	6. RS-485 Port 3 RX
7. RS-232 TX OUT	7. RS-485 Port 4 TX
8. RS-232 RX OUT	8. RS-485 Port 4 RX

Diagnostic Port

The Diagnostic Output of the DSX-1035 can be used to monitor the transmit or receive side of the data sent through the DSX-1035. If both the diagnostic out switches is turned On at the same time, both the transmit and receive will echo out the RS-232 diagnostic output. This Data can be monitored with a PC using KB2CW.exe from the WinDSX directory.

Revised and Non-Revised Controllers

When adding a non-revised controller to a series of new controllers it is required that a DSX-1035 or DSX-485T be placed on the comm. loop after the master or any Sub. The non-revised controllers can be placed on one of the outputs of these devices while the remaining revised controllers are connected to a separate output.

Note /// A DSX-485T can be added to any non-revised controller giving it revised controller communications compatibility.

Master or Sub to DSX-1035 and DSX-1035 to Master or Sub Communications

Use the charts below for terminal-to-terminal wiring information on Controller to DSX-1035 and DSX-1035 to Controller communication connections. The charts provide wiring information for each generation DSX Controller connecting to every other generation of Controller through a DSX-1035.

<u>1021 Master To 1035 Quad</u>	
485 IN to 485 IN	
41, TX+	-- 3, RX+
42, TX-	-- 4, RX-
43, RX+	-- 1, TX+
44, RX-	-- 2, TX-
<u>1021 SUB To 1035 Quad</u>	
485 OUT to 485 IN	
45, TX+	-- 1, TX+
46, TX-	-- 2, TX-
47, RX+	-- 3, RX+
48, RX-	-- 4, RX-
<u>1035 Quad To 1021 SUB</u>	
485 OUT to 485 IN	
TX+	-- 43, RX+
TX-	-- 44, RX-
RX+	-- 41, TX+
RX-	-- 42, TX-

<u>103x Master To 1035 Quad</u>	
485 IN to 485 IN	
41, TX+	-- 3, RX+
42, TX-	-- 4, RX-
43, RX+	-- 1, TX+
44, RX-	-- 2, TX-
<u>103x SUB To 1035 Quad</u>	
485 OUT to 485 IN	
45, TX+	-- 1, TX+
46, TX-	-- 2, TX-
47, RX+	-- 3, RX+
48, RX-	-- 4, RX-
<u>1035 Quad To 103x SUB</u>	
485 OUT to 485 IN	
TX+	-- 43, RX+
TX-	-- 44, RX-
RX+	-- 41, TX+
RX-	-- 42, TX-

<u>1022 Master To 1035 Quad</u>	
485 IN to 485 IN	
59, TX+	-- 3, RX+
58, TX-	-- 4, RX-
57, RX+	-- 1, TX+
56, RX-	-- 2, TX-
<u>1022 SUB To 1035 Quad</u>	
485 OUT to 485 IN	
55, TX+	-- 1, TX+
54, TX-	-- 2, TX-
53, RX+	-- 3, RX+
52, RX-	-- 4, RX-
<u>1035 Quad To 1022 SUB</u>	
485 OUT to 485 IN	
TX+	-- 57, RX+
TX-	-- 56, RX-
RX+	-- 59, TX+
RX-	-- 58, TX-

<u>1040CDM w/ Master To 1035 Quad</u>	
485 IN to 485 IN	
5, TX+	-- 3, RX+
6, TX-	-- 4, RX-
7, RX+	-- 1, TX+
8, RX-	-- 2, TX-
<u>1040CDM w/ SUB To 1035 Quad</u>	
485 OUT to 485 IN	
9, RX+	-- 1, TX+
10, RX-	-- 2, TX-
11, TX+	-- 3, RX+
12, TX-	-- 4, RX-
<u>1035 Quad To 1040CDM w/ SUB</u>	
485 OUT to 485 IN	
TX+	-- 7, RX+
TX-	-- 8, RX-
RX+	-- 5, TX+
RX-	-- 6, TX-

AptiQ Readers and Keypads

There are several models of AptiQ available from DSX. All AptiQ readers follow a similar wiring scheme. Each reader or keypad is shipped with documentation. If further documentation is required, please visit www.xceedid.com or call 303-273-9930.

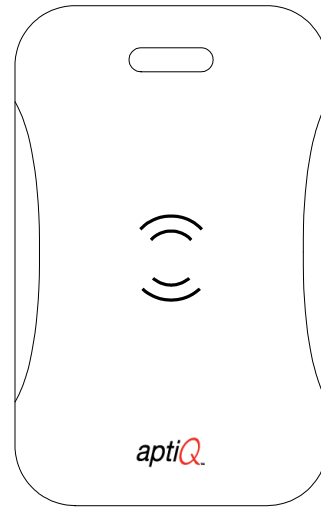
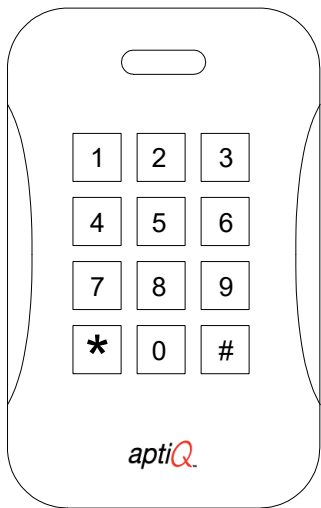

Description

AptiQ Proximity Readers provide a Wiegand style of data interface to the DSX system. The proximity readers provide a single multi-color LED that is used to display the door status and an optional beeper.

LED Operation

Red = Door is Secure (Locked)

Green = Door is Open (Unlocked)

Red/Green Flashing = Reader is in Lockout Mode.

Red /Green Flashing twice = Access Denied

Lockout Mode

Lockout occurs when the number of consecutive denials allowed at a reader has been exceeded. The reader will remain in the lockout mode for 30 seconds. During the Lockout, the reader LEDs should switch rapidly from red to green for 30 seconds and it will not read ANY cards whatsoever. The number of consecutive denials allowed at a reader is determined under Location in the Database portion of the WinDSX software.

Sounder Control

The Yellow wire is used in most AptiQ readers for an optional Sounder when connected to the Pre-Warn output.

Presenting or using a Proximity Card

Proximity Cards should be presented to the read head with the body of the card parallel to the read head. The card should be held steady and not waved at the reader. Cards can be read through a purse or wallet that does not have metal between the card and the reader. To test the read range of a proximity reader, the card should be placed in front of the reader and then removed from the read area until it is successfully read. Do not hold the card in the read area and move it toward the reader, since pushing the card slowly toward the reader will not accurately reflect the read range.

Setting the AptiQ MTK15 Keypad to 26 Bit Output

How to Configure the MTK15 Keypad to Output 26 Bits and a Fixed Facility Code.

Step1: Power cycle the reader to initialize the reader and enter the following code on the keypad within the 1st minute of initialization: * 8 8 8 8 9 9 9 9

The led turns green and a short triple-beep indicates that the reader is ready to have the keypad format entered on the keypad.

Step2: Within 5 seconds enter # followed by the fixed facility code from the keypad. The facility code must be a 3-digit decimal number between 000 and 255.

Facility code examples:

Enter # 0 9 6 for fixed facility code 96

Enter # 1 2 8 for fixed facility code 128

A triple beep/green led flash will indicate a successful configuration of the keypad.

Step3:

To use the keypad in this mode enter your Code and press #. The reader sends the Code (packaged as a 26-bit Wiegand output along with the fixed facility code). The Code must be a number between 1 and 65535.

RESET Back to Factory Default:

To set the reader in '8-bit burst keypad mode (default), follow these 2 steps:

Step1: Power cycle the reader to initialize the reader and enter the following code on the keypad within the 1st minute of initialization: * 8 8 8 8 9 9 9 9

Step2: You have 5 seconds to enter the keypad format on the keypad:

Enter * 0.

A triple beep/green led flash will indicate a successful configuration of the keypad.

In this mode the keypad sends an 8-bit burst to the panel for every key press

NOTE /// For specific purpose and setup descriptions regarding 26-bit and 8-bit operations refer to the "Card Plus PIN / Card or PIN section of this manual.

AptiQ Proximity Reader Connected to a DSX-1022

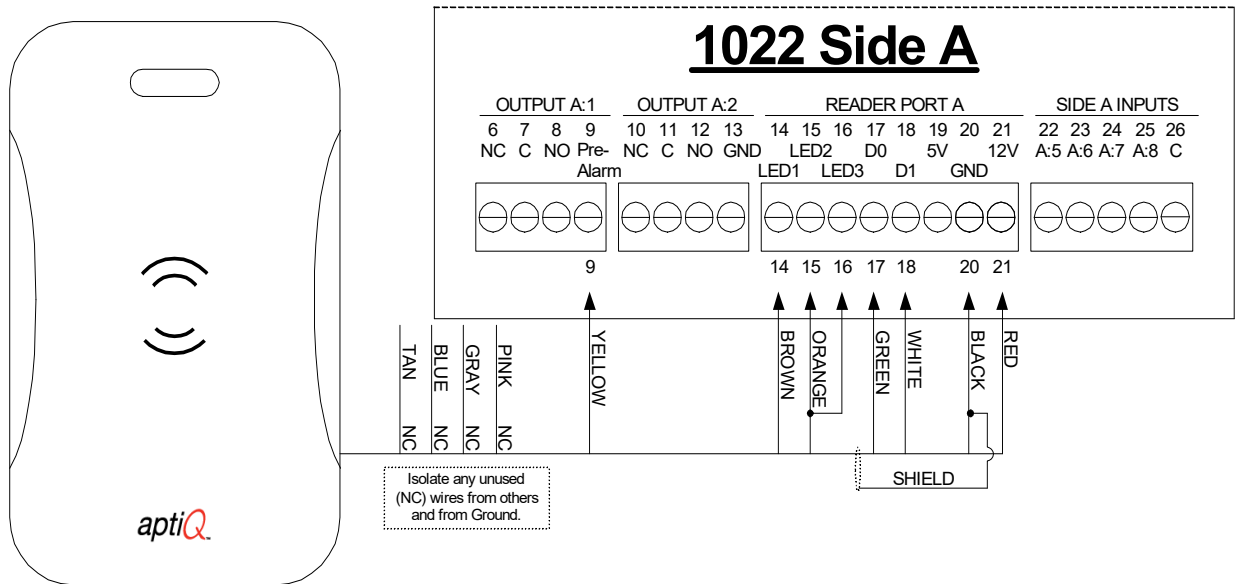

Device Types

The proper clock and data device type can be found in the F1 Help screen for Device Type under Device in the Database program. If the proper device type cannot be determined, it may be necessary to send a sample of 5 cards to DSX for evaluation.

Cardkey Readers

Description

The Cardkey™ L40 and D40 can be used with DSX hardware with the use of a CKI-C. The CKI-C should be used with the L40 reader only and the CKI-C + DS400-IB should be used with the D40 reader/keypad.

The Cardkey™ Magstripe Swipe Reader and the Magstripe Reader Keypad also work with the DSX System. These readers have a one wire Wiegand output and require the use of a CKI-C and CKI-C + DS400-IB respectfully.

Cardkey™ readers that have a two-wire data output do not require the CKI interface boards.

WinDSX allows the use of both Cardkey and DSX cards through the same reader. New Cardkey cards can be used in standard Sensor Swipe Readers.

Cardkey™ readers must be integrated into the DSX system by utilizing a DSX-CKI interface board at each DSX-1022 controller that is to accept data from a Cardkey reader. Each DSX-CKI board will accept data from 2 Cardkey readers and make the necessary conversion of the data to bring it into the DSX-1022 controller via the two reader ports.

The DS400-IB converts the 3x4 output of the Cardkey keypad to a Wiegand output. The DS400-IB accepts and converts 1 keypad only. For two reader keypad combinations (D40) a single CKI-C or CKI-K and two DS400-IB modules are required.

The CKI-C or CKI-K and DS400-IB can be used attach Cardkey D40 reader / keypads with the DSX-1022. One CKI (C or K) per controller and one DS400-IB per D40.

Tools Required

The CKI-C is equipped with AMP/MTA connectors. The wires are attached to these connectors with a special tool. The AMP part number for the tool is 59803-1 and the description is MTA-100 Maintenance Hand Tool. This tool should be available at most electrical supply stores.

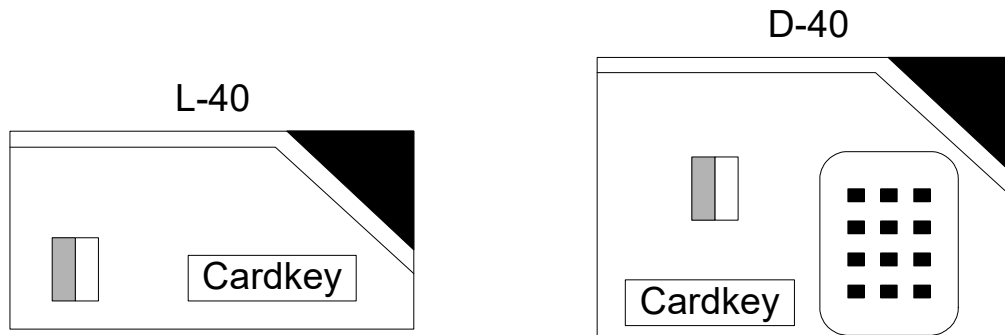

LED Operation

Red = Door is Secure (Locked)

GREEN = Door is Open (Unlocked)

Red & GREEN Flashing = Reader is in Lockout Mode.

Red Flash / GREEN Off = Access Denied

The Green LED flashes twice for Access Denied on the DSX-1022.

Lockout Mode

Lockout occurs when the number of consecutive denials allowed at a reader has been exceeded. The reader will remain in the lockout mode for 30 seconds. During the Lockout the reader LEDs should switch rapidly from red to green for 30 seconds and it will not read ANY cards whatsoever. The number of consecutive denials allowed at a reader is determined under Location in the Database portion of the WinDSX software.

Access Denied

If an Access Denied indicator is desired at the reader, a jumper may be placed between LED output 2 and 3 of the DSX-1022 Controller. LED output 3 provides 2 quick pulses when a card is denied access. By placing a jumper between outputs 2 and 3, the card reader LED will give two red flashes when a card is denied access.

Connections and Programming

The following schematics show the CKI-C and the CKI-K. The CKI-C is used for interfacing two Cardkey readers to the DSX-1022. The CKI-K may be used to interface the Cardkey reader/keypad combination units but requires the addition of a DS400-IB. If connecting the L40 reader to a CKI-C omit the Keypad wiring portion of the schematic.

Non encrypt with BCD keypad - Device Type CW

If using Cardkey Wiegand readers reverse the Data 1 and Data 0 wires from the CKI module so that the wire marked Data 1 on the module goes to Data 0 on the controller and the wire marked Data 0 on the module goes to Data 1 on the controller. If using standard Sensor readers, then connect as you normally would. That is Green to Data 0 and White to Data 1.

Non encrypt with Wiegand keypad - Device Type D0

Set the Reverse Card Data flag under device to N. If using Cardkey Wiegand readers reverse the Data 1 and Data 0 wires from the CKI module so that the wire marked Data 1 on the module goes to Data 0 on the controller and the wire marked Data 0 on the module goes to Data 1 on the controller. If using standard Sensor readers, then connect as you normally would. That is Green to Data 0 and White to Data 1.

Encrypt with BCD keypad - Device Type CE

If using Cardkey Wiegand readers reverse the Data 1 and Data 0 wires from the CKI module so that the wire marked Data 1 on the module goes to Data 0 on the controller and the wire marked Data 0 on the module goes to Data 1 on the controller. If using standard Sensor readers, then connect as you normally would. That is Green to Data 0 and White to Data 1.

Encrypt with Wiegand keypad - Device Type E3

If using Cardkey Wiegand readers reverse the Data 1 and Data 0 wires from the CKI module so that the wire marked Data 1 on the module goes to Data 0 on the controller and the wire marked Data 0 on the module goes to Data 1 on the controller. If using standard Sensor readers, then connect as you normally would. That is Green to Data 0 and White to Data 1.

Magnetic Stripe Readers and Cards - Device Type CM

The device type used for Cardkey magnetic stripe readers is CM. Make connections to the interface as Data 1 to Data 1, Data 0 to Data 0. Reverse Card Data may have to be Yes.

Magnetic Stripe Readers and Cards with PIN - Device Type L7

To add Card Plus PIN operation to a Cardkey magstripe reader one can parallel the connection of an 8bit Wiegand keypad to the reader port. Make connections to the controller as Data 1 to Data 1, Data 0 to Data 0. Within the Location settings "Enable Card + P.I.N. Operation" must be checked and within each Device "Reverse Card Data" must be Enabled, with a check mark. The DSX part number for the suggested keypad is DS-12-8W.

Non-Encrypted Cards - Device Type F6

To add 26bit cards to an existing 34bit Cardkey HID system that uses Device Type CW. Order HID 26bit Reverse, set the Device Type to F6, "Reverse Card Data" must be Enabled at each Device, and make connections with Data 1 to Data 1, Data 0 to Data 0 at each reader connection of a Controller.

Additional Programming Notes

When using Cardkey Device Types, you must also verify the following programming considerations. Under Location, Card Readers with Keypads must be enabled. Card Reader TZ and/or Keypad TZ must have an active time zone to enable or disable the reader/keypad.

DSX Controllers with Cotag Readers and CKI Modules

When using the older and smaller CKI modules along with Cotag readers and version 12 or WinDSX software a modification is required at the reader connection. Add a 200 Ohm ½ watt resistor in series with the 5vdc supply to the reader.

When using the newer CKI modules along with Cotag readers and version 12 or WinDSX software the required modification includes a .01 mfd capacitor across the data line from the reader to negative. That is that one leg of the capacitor will connect to the Cotag readers out wire and the other will connect to negative. This should be done at the CKI board.

CKI-C Connected to a DSX-1022

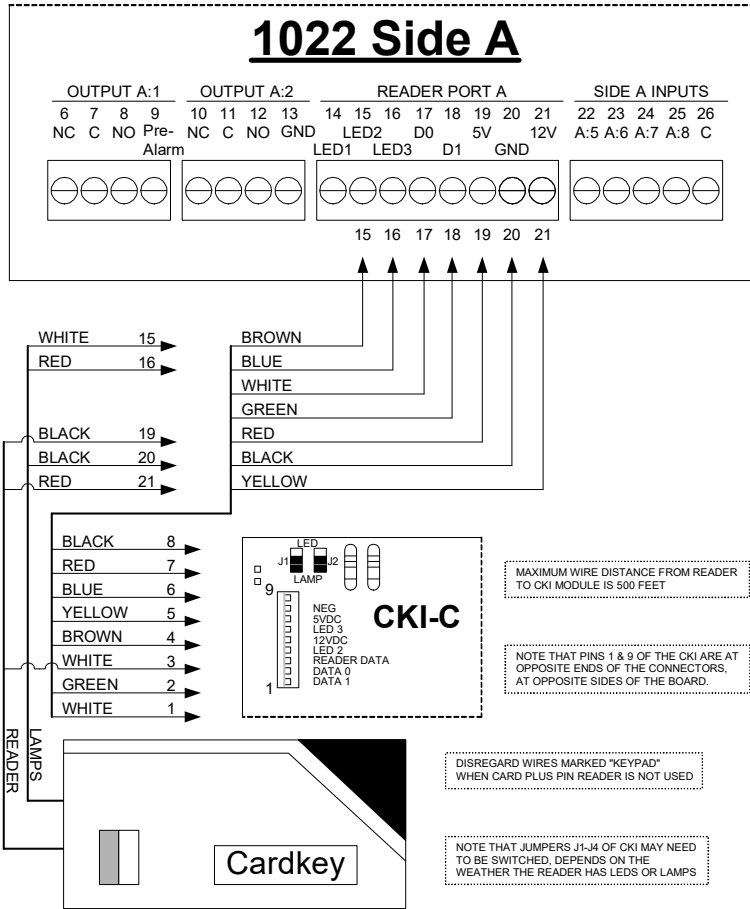

CKI-K Connected to a DSX-1022

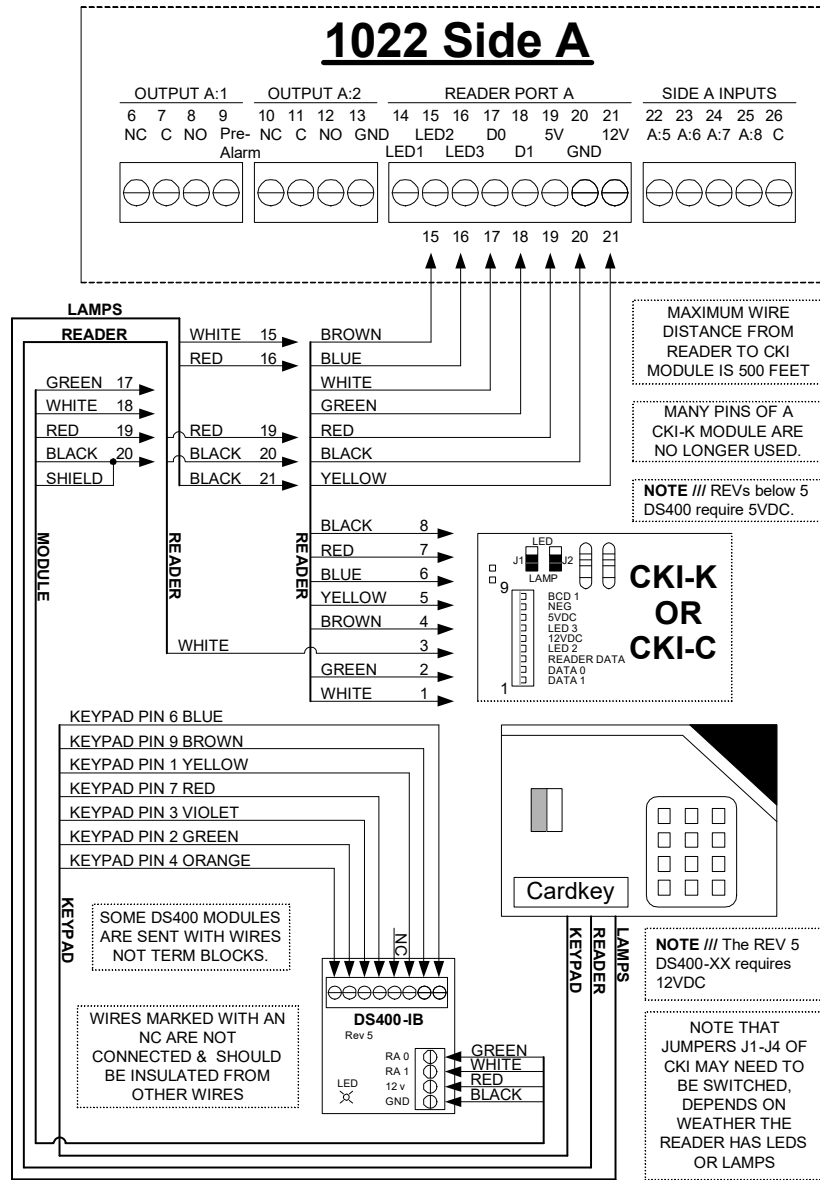

Note /// The DSX Controllers no longer accept a CKI-K module. The DS400-IB module converts the 3x4 matrix output of the keypad to an 8bit Wiegand Output that connects to the reader port.

HID Proximity Readers

Which includes the latest technologies from HID.
 HID iCLASS, iCLASS SE and multiCLASS readers.

Older HID readers consist of two pieces of equipment, the scanner, and the reader. The scanner is the read head where the card is presented. The reader consists of the electronics that decodes the data read by the scanner and transmits that data to the DSX controller. New HID Readers are unitized with all electronics built in to one unit.

The LED on the older scanner is controlled by the reader and not the DSX-1022. The LED is normally on and flashes off when a card is presented. This flash does not indicate that the DSX-1022 accepted the card, it only indicates that the reader saw the data transmitted from the scanner. This is true with both the old 5300 series readers and the original PL6005 ProxPoint Readers. All other HID prox readers have LED control from the Access Panel.

HID – CardKey – Northern – Additional Card Support

HID readers used with 34bit Cardkey formatted cards connect directly to the DSX-1022 Controllers. These readers do not need the CKI-C/K modules and wire to the panels according to the wiring diagrams that follow.

The Device Type to use with the HID-Cardkey Cards is F6. It is also necessary to set the Reverse Card Data field to Yes and give the Card Reader TZ field an active Time Zone. Additional Cards can be ordered from DSX to work with the existing 34bit Cardkey Cards. The cards are specified as HID 26bit Reverse Order Cards.

HID readers used with Northern formatted cards can be connected directly to the DSX-1022 Controllers. The Device Type to use with the HID-Northern Cards is B6. Additional Cards can be ordered from DSX to work with the existing Northern Cards. The cards must be specified as HID DSX 33bit.

Shown below is the HID 5355 ProPro Plus reader.

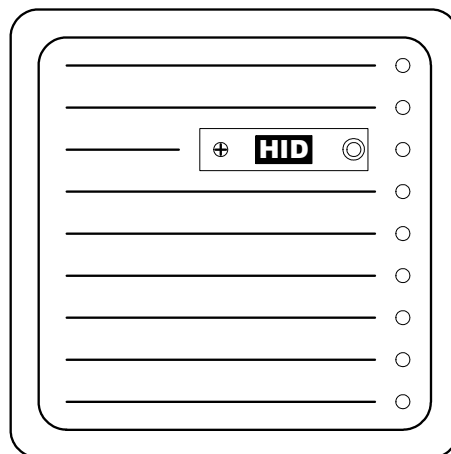

6005 ProxPoint & 6110 iCLASS R30 connected to a DSX-1022

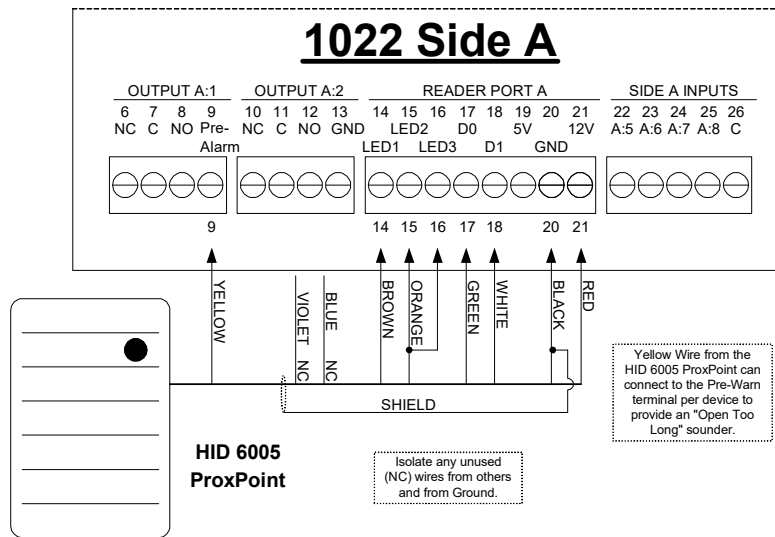

Note /// Early versions of the ProxPoint did not include several of the features as noted on this page.

5395 Thin Line II connected to a DSX-1022

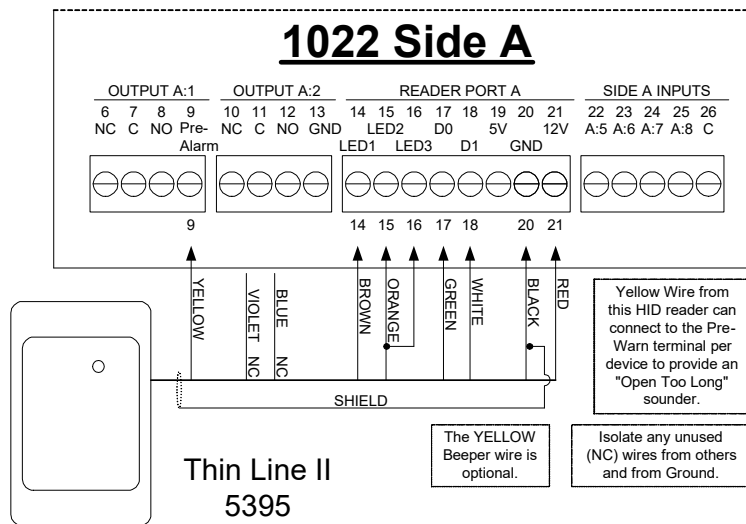

5355/ 6030 Prox Pro Plus connected to a DSX-1022

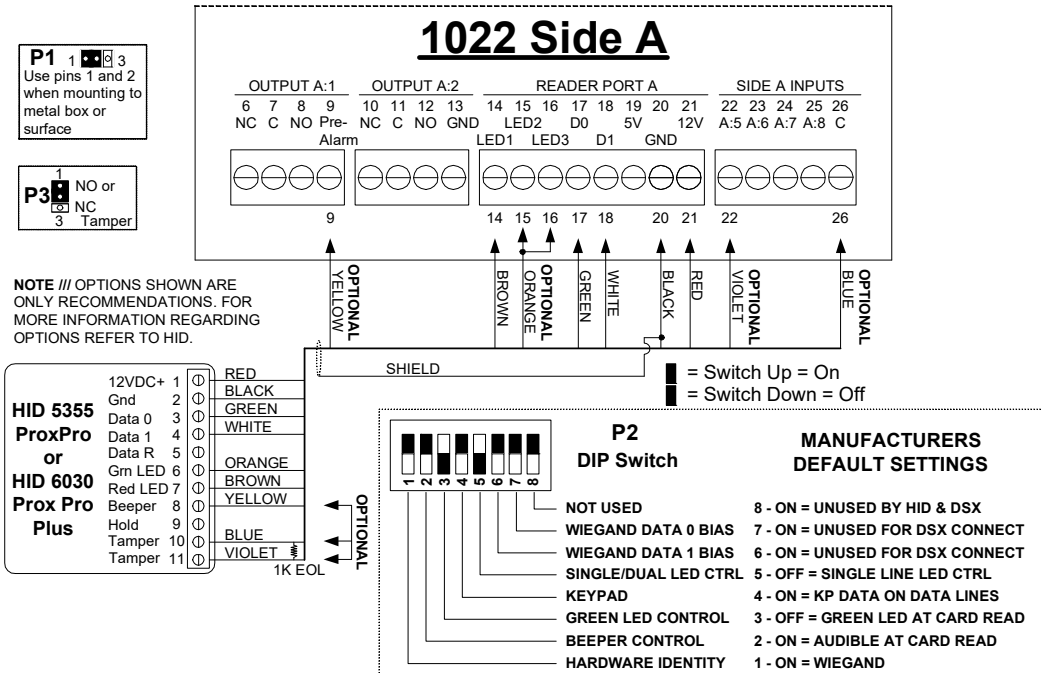

DSX and HID now offer the HID Prox Pro 5355-8 which can provide a Card + PIN scenario or HID Prox Pro 5355-26 for a Card or PIN scenario. These formats require connection to only one DSX reader port or Device. Use caution when ordering due to the model being specific to operation.

The HID Prox Pro 5355-8 will require “Enable Card + PIN Operation” being enabled and “Number of digits in PIN Code” in the Location settings as well as a time zone being assigned to the “Keypad TZ” of the Device and PIN numbers assigned to the cardholders that must access the controlled door. The HID 5355-8 reader will require a card read during the active portion of the TZ set at the Reader TZ and would require a 4-7digit code to be entered after the card read.

The HID Prox Pro 5355-26 only requires that the code number entered at the keypad section be within the range of 1-65,535 and that number be set as a “Code #” for the cardholder. With this model the cardholder’s card is presented to the Cardreader or the cardholders “Code #” is entered at the Keypad for a Card or PIN style of operation. Card or PIN provides that either the Card or Card Number (PIN) be provided to grant access.

5365 Mini Prox connected to a DSX-1022

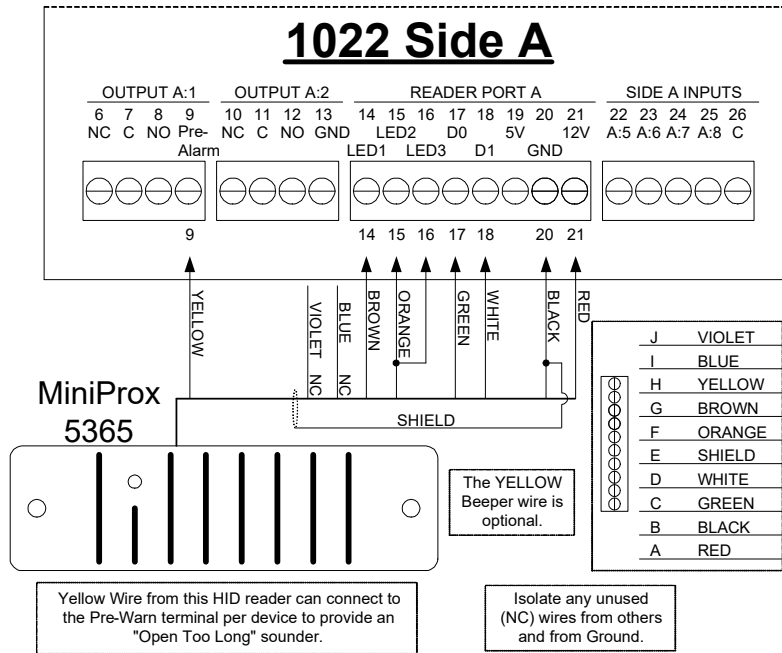

5375 Maxi Prox connected to a DSX-1022

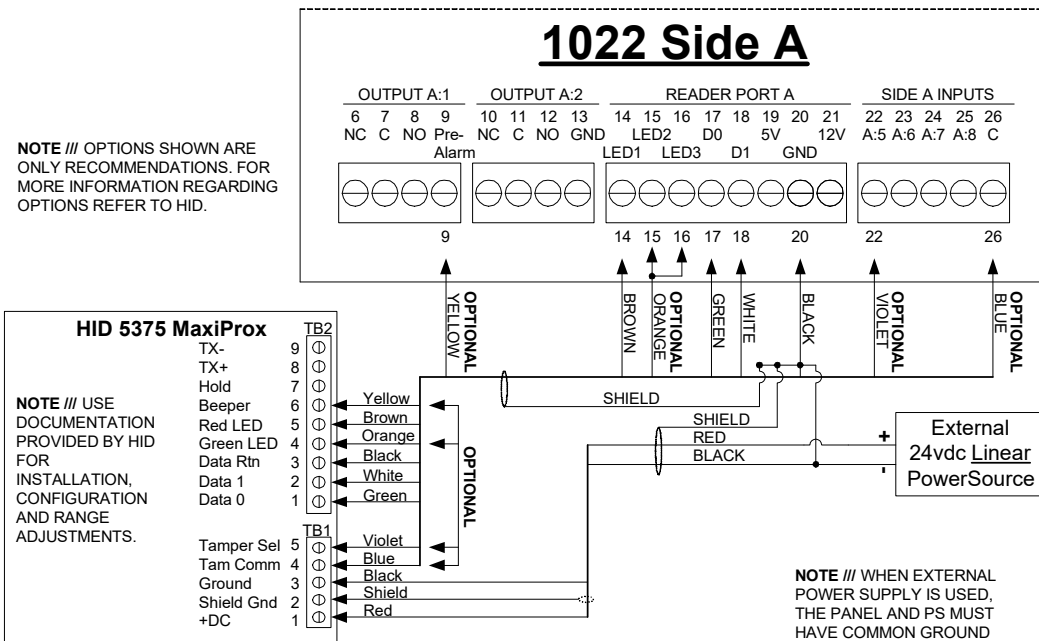

HID/Sensor Engineering Wiegand Card and Key Readers

There are five different models of Sensor Readers available from DSX. All Sensor Wiegand readers follow the same wiring scheme. The following diagrams show the connections from a W-S Wiegand (Sensor 30387) reader to DSX panels. This same schematic is used to connect any of the Wiegand (Sensor) readers to the DSX-1022 controllers.

W-S Wiegand Swipe
Sensor 30387

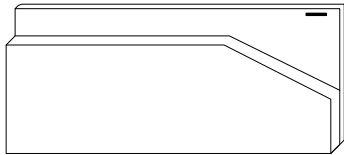

W-T Wiegand Turnstile
Sensor 31503

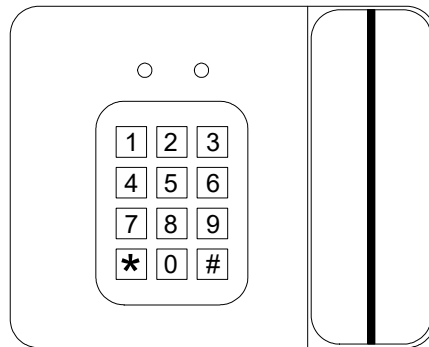
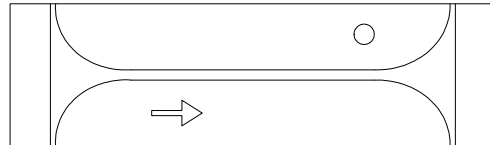

W-SPIN Wiegand
Swipe with Keypad
Sensor 3103560

W-I Wiegand Insertion
Sensor 31880

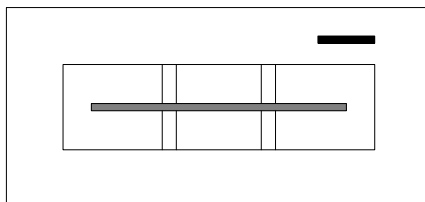

W-K Wiegand Key Insertion
Sensor 32005

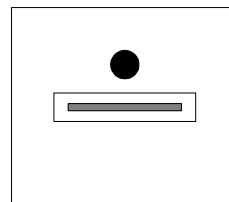

Note /// It is recommended to use 18 AWG wire with the 5V version of this reader due to voltage drop. If necessary, use a 12V regulator at the reader. Connect the 12V power of the panel to the regulator and the 5V output of the regulator to the reader. This will keep the 5V power constant and compensate for a long wire run.

Note /// New Wiegand Readers that are marked HID are 5-12V capable with 12V being the recommended voltage.

Description

HID/Sensor Wiegand Readers provide a Wiegand style of data interface to the DSX system. Sensor Engineering readers utilize a multi-color LED that is used to display the following:

LED Operation

Red = Door is Secure (Locked)
Green = Door is Open (Unlocked)
Red & Green Flashing = Reader is in Lockout Mode.
Two Green to Red Flashes = Access Denied

Lockout Mode

Lockout occurs when the number of consecutive denials allowed at a reader has been exceeded. The reader will remain in the lockout mode for 30 seconds. During the Lockout the reader LEDs should switch rapidly from red to green for 30 seconds and it will not read ANY cards whatsoever. The number of consecutive denials allowed at a reader is determined under Location in the Database portion of the WinDSX software.

Access Denied Indicator

If an access denied indicator is desired at the reader, a jumper may be placed between LED 2 and 3 of the DSX-1022 panel. LED 3 provides 2 quick pulses when a card is denied access. By placing a jumper between LED outputs 2 and 3, the card reader LED will give two Green to Red flashes when a card is denied access.

Blue Wire

The blue wire from the reader puts the reader into a buffer mode. DSX does not use this wire. Be sure to leave the blue wire disconnected but insulated. If this wire shorts to ground the reader will stop reading cards until the ground is removed.

Card Insert Reader

When using the W-I Card Insertion Reader (Sensor 31880), the Reverse Card Data field must be set to Yes under Device in the Database program and the Device Type is set to WE or D5. The W-I card insertion reader transmits the card data to the panel inverted. The DSX panel has to be instructed to perform the reverse card read so it will process the card data properly.

Key Insert Reader

When using the W-K Key Insert Reader and 26bit keys with Firmware Version 279 or lower, the key must be inserted into the reader with the dimple on the key facing away from the reader LED. Use Device Type WE for Firmware Versions 279 or lower. With Firmware Version 280 - 305, the key may be inserted in either direction. The key will be read as the same number. Use Device Type C5. This does not apply to the new 33bit format Device Type D5.

HID/Sensor Readers connected to a DSX-1022

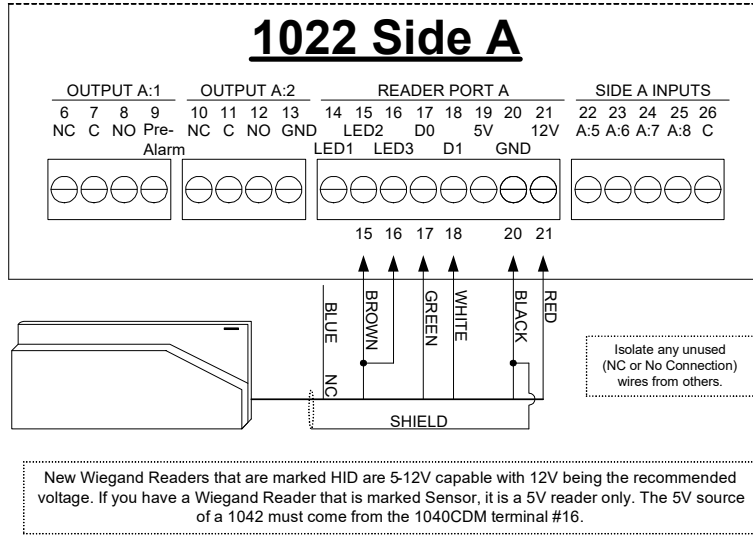

Power

The new units manufactured by and labeled as HID are now 5-12 VDC compatible. Earlier models were 5 VDC only.

Device Types

These Sensor Wiegand readers will read data from almost any Wiegand card. The DSX-1022 must have the proper device type defined to match the format of the cards to be used. If you are using older standard DSX cards, the Device Type will be WE. If you are using new standard DSX cards, the Device Type will be D5. Many systems manufacturers create their own custom card format. If you are using existing Wiegand cards, view the help menu under Device Type and enter the proper device type for the cards you wish to use. If you do not know the format of the card, contact DSX Technical Support.

Indala / Motorola Proximity Readers

The following Indala / Motorola proximity readers are sold and supported by DSX. The ASR and PR Series readers look similar but are not compatible with each other and use different cards. The PR Series is the older version of proximity used for existing systems with PR Series cards. The ASR Series readers only work with ASR cards and should be used for all new installations. ASR and PR Series Readers with a 32bit output use the Device Type 32 under Device in the Database Program. New ASR readers and cards are 33 bit and use a Device Type of D5. Starting in July of 1996, all new ASR model readers are indoor/outdoor rated and can be ordered in beige or black except the ASR500 and 503, which are black only. The ASR-500, which is not shown on this page, connects to the controller in the same manner as the ASR-503. The 600 series replaced the 500 series late in 1998.

ASR-501

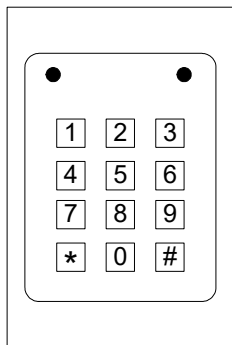

ASR-603/
503/PR-3



ASR-605/
605/PR-5

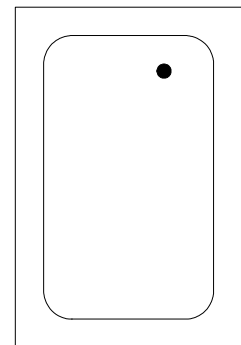

ASR-110/610/
620/PR-10

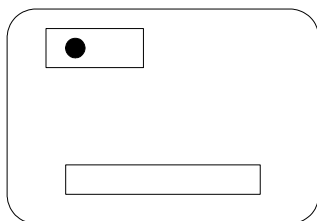

ASR-120 / PR-20

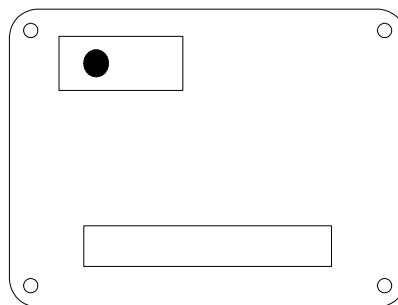

ARE / RE
Module

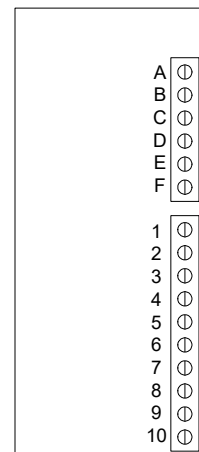

Description

Indala Proximity Readers provide a Wiegand style of data interface to the DSX system. The proximity readers provide a single multi-color LED that is used to display the door status and an optional beeper.

LED Operation

Red = Door is Secure (Locked)

Green = Door is Open (Unlocked)

1 Short Beep = Access Granted

Amber Flashing & Beeping = Reader is in Lockout Mode.

Two Beeps = Access Denied

Lockout Mode

Lockout occurs when the number of consecutive denials allowed at a reader has been exceeded. The reader will remain in the lockout mode for 30 seconds. During the Lockout, the reader LEDs should switch rapidly from red to green for 30 seconds and it will not read ANY cards whatsoever. The number of consecutive denials allowed at a reader is determined under Location in the Database portion of the WinDSX software.

Access Denied

If an Access Denied indicator is desired at the reader, a jumper must be placed between LED 2 and LED 3 of the DSX-1022 controller. LED 3 provides 2 quick pulses when a card is denied access. By placing a jumper between LED 2 and 3, the card reader LED will give two Green to Red flashes when a card is denied access. For an audible access denied indicator connect the Blue wire to terminal 11 for 2 short beeps indicating access denied.

Unitized Readers

The ASR-500, 503, 505, 110, 112, 603, 605, 610, 620, PR-10, and PR-12 are self-contained readers with the reader head and processing unit together in the same housing. The first of the following schematics is for the Unitized Readers that connect directly to the DSX-1022.

Readers with Electronics Module

All Indala readers not mentioned above provide a separate read head that sends information back to the remote electronics module where the data processing unit is housed. The remote electronics module may be located up to 50 feet from the read head and up to 500 feet from the DSX-1022 panel. The second schematic is for all Indala readers that require the use of a remote electronics module to interface the reader to the DSX-1022

Presenting or using a Proximity Card

Proximity Cards should be presented to the read head with the body of the card parallel to the read head. The card should be held steady and not waved at the reader. Cards can be read through a purse or wallet that does not have metal between the card and the reader. To test the read range of a proximity reader, the card should be placed in front of the reader and then removed from the read area until it is successfully read. Do not hold the card in the read area and move it toward the reader, since pushing the card slowly toward the reader will not accurately reflect the read range.

Mounting

Proximity readers may be recessed 1 to 2 inches behind any non-conductive material. Effective read ranges will be reduced when readers are recessed behind a wall.

ASR-500, 501, 503, 505, 110, 112, 603, 605, 610, PR10, and PR-12 Connected to a DSX-1022

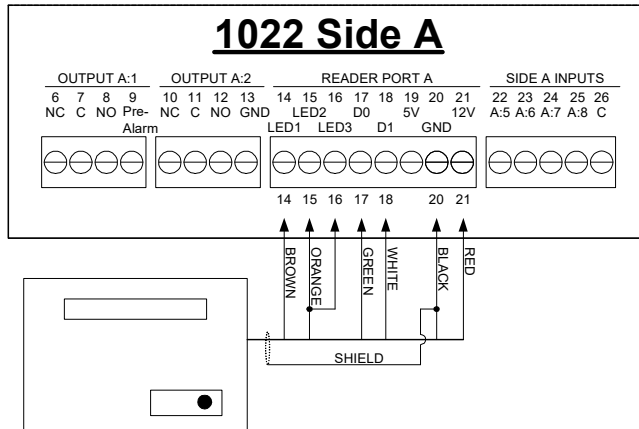

DSX and Motorola now offer the ASR 501-8 which can provide a Card + PIN scenario or ASR 501-26 for a Card or PIN scenario. These formats require connection to only one DSX reader port or Device. Use caution when ordering due to the model being specific to operation.

The ASR 501-8 will require “Enable Card + PIN Operation” being enabled and “Number of digits in PIN Code” in the Location settings as well as a time zone being assigned to the “Keypad TZ” of the Device and PIN numbers assigned to the cardholders that must access the controlled door. The ASR 501-8 reader will require a card read during the active portion of the TZ set at the Reader TZ and would require a 4–7-digit code to be entered after the card read.

The ASR 501-26 only requires that the code number entered at the keypad section be within the range of 1-65,535 and that number be set as a “Code #” for the cardholder. With this model the cardholders’ card is presented to the Cardreader or the cardholders “Code #” is entered at the Keypad for a Card or PIN style of operation. Card or PIN provides that either the Card or the Card Number (PIN) be provided to grant access.

Separate Green LED Control

The Orange wire is used for separate Green LED control from LED 2.

Sounder Control

The Blue wire is used for an optional Sounder connected to LED 3 or the Pre-Warn output.

Note /// The PR-Series Readers do not have two LED Control lines. Use the Brown wire to connect to LED 1 or 2.

Device Types

Older Indala proximity readers purchased from DSX will use a Device Type of 32. Newer Indala proximity readers purchased from DSX will use a Device Type of D5. If the readers are from an existing system, a different device type may be used. Reference the (F1) Help screen for Device Types under Device in the Database Program. If there are difficulties determining the device type, contact DSX Technical Support for assistance.

ASR-620+ PowerProx Readers Connected to a DSX-1022

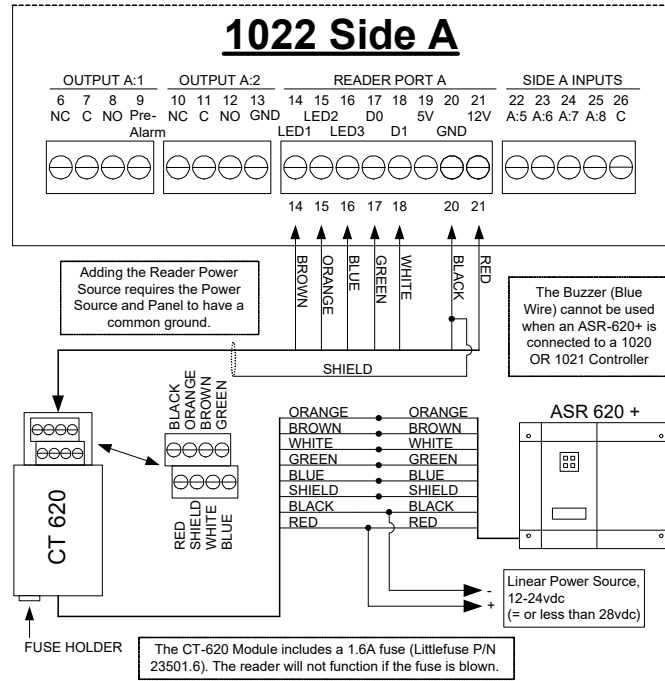

ASR-620+ PowerProx Wiring Distance Chart

PowerProx

The PowerProx connects to the controller as shown but requires a separate 12V or 24V

ASR-620+ to CT-620 Cable Length 3 or 4 conductor w/shield			CT-620 to Controller Cable Length 6 or 8 conductor w/shield		Power Supply to CT-620 2 conductor	
Cable Size	Max Length 12v	Max Length 24v	Cable Size	Max Length	Max Length	
24awg	20'	30'	22awg	500'	18"	
22 awg	30'	44'	18awg	500'		
18 awg	80'	120'				

linear power supply with common ground, further setup, adjustments and tuning. Please see the manual that comes with the reader for more information.

Separate Green LED Control

The Orange wire is used for separate Green LED control from LED output # 2.

Sounder Control

The Blue wire is used for an optional Sounder connected to LED 3 or the Pre-Warn output.

Device Types

If this is a Prox Reader with a 26 or 33bit DSX format the Device Type would be D5. If this is a PR-10 with the AT&T™ format the Device Type would be “F9”. Reference the (F1) Help screen for Device Types under Device in the Database Program.

Mercury MR-10/20 Magnetic Stripe Reader

The MR-10 is an indoor/outdoor magnetic stripe reader used to read existing customer cards or cards the customer is encoding. The MR-20 is identical to the MR-10 but also has an integral keypad for card and PIN applications. Both units will mount on a door mullion and can be mounted to a single gang electrical box with the use of a trim plate. The MR-10 and MR-20 Magnetic Stripe Readers will work with many existing magnetic stripe card formats. Many different Device Types under Device in the Database Program will allow these readers to work with existing cards. For DSX to assist, it may be necessary for a sample of 5 cards to be sent to DSX for evaluation.

MR-10

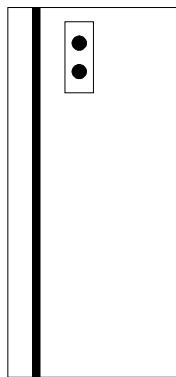

MR-20

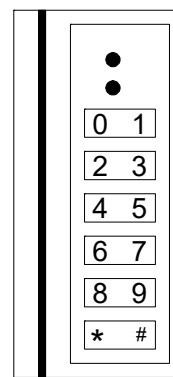

MR-10 Card Reader Description

The MR-10 Magnetic Stripe Reader is primarily used in conjunction with existing magnetic stripe cards. The MR-10 provides a Clock and Data style interface to the DSX-1022. The MR-10 incorporates two LED’s (Red and Green) that are used to display the following:

Card Reader LED Operation

- Red = Door is Secure (Locked)
- Green = Door is Open (Unlocked)
- Red & Green Flashing = Reader is in Lockout Mode.
- Two Green and Red Flashes = Access Denied

MR-20 Card Reader Description

The MR-20 is the same as the MR-10 with the addition of an integral keypad. The MR-20 is the same in every way except for the keypad. The Green and Red LED are used to indicate the following.

Card Reader Keypad LED Operation

- Red = Door is Secure (locked)
- Green = Door is Open (Unlocked)
- Green to Red Flashing slow = Enter Pin
- Two Green to Red fast Flashes = Access Denied
- Green to Red Flashing fast = Reader is in Lockout Mode

Lockout Mode

Lockout occurs when the number of consecutive denials allowed at a reader has been exceeded. The reader will remain in the lockout mode for 30 seconds. During the Lockout the reader LEDs should switch rapidly from red to green for 30 seconds and it will not read ANY cards whatsoever. The number of consecutive denials allowed at a reader is determined under Location in the Database portion of the WinDSX software.

Access Denied

If an Access Denied indicator is desired at the reader, a jumper may be placed between LED 2 and 3 of the DSX-1022 panel. LED 3 provides 2 quick pulses when a card is denied access. By placing a jumper between LED outputs 2 and 3, the card reader LED will give two green and red flashes when a card is denied access.

Special Wiring Information

LED Pull-up Resistor: Connect a 1K resistor between LED 2 and 5VDC. By placing the resistor between the 5VDC power and the LED wire, the Red LED will be on when the door is locked, and the Green LED will be On when the door is unlocked. When the reader is used in the clock and data mode, which is typical for existing card applications, connect the Green wire of the reader to the terminal labeled White. Also connect the White wire from the reader to the terminal labeled Green on the silkscreen of the panel.

Reader Switch Settings

Reader Output	MR Switch Setting	Device Type
Wiegand	1, 2, 3 Off / 4 On	Wiegand (WE)
Clock & Data	1,2 Off / 3, 4 On	Clock/Data (A5 for DSX cards)
Northern NR1 32 bit	1, 2, 3, 4 On	CO, D4
Northern NR1 26 bit	1, 4 On / 2, 3 Off	WE

Pyramid Proximity Reader

The following is a wiring diagram for the Pyramid Proximity Reader connected to DSX 1022 Controller. This reader is not sold by DSX but is compatible. The wiring information is accurate when this document was published but is subject to change. It should be noted that DSX does not sell or support this reader.

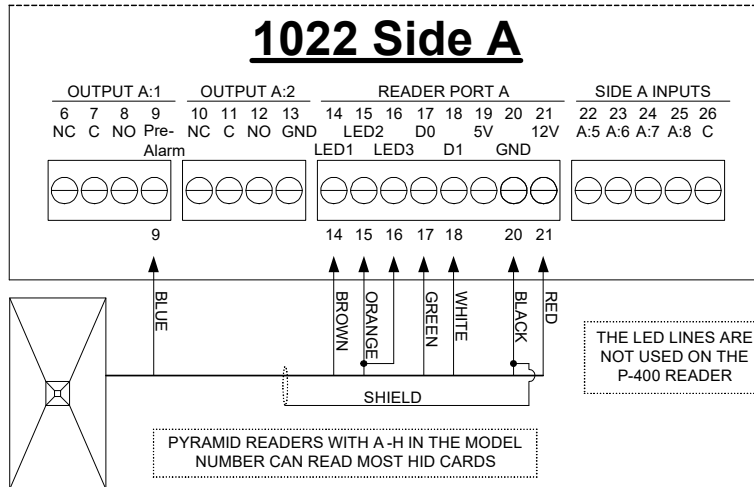

Lockout Mode

Lockout occurs when the number of consecutive denials allowed at a reader has been exceeded. The reader will remain in the lockout mode for 30 seconds. During the Lockout, the reader LEDs should switch rapidly from red to green for 30 seconds and it will not read ANY cards whatsoever. The number of consecutive denials allowed at a reader is determined under Location in the Database portion of the WinDSX software.

Device Types

The proper device type may be found in the F1 Help screen for Device Type under Device in the Database program. If the proper device type cannot be determined, it may be necessary to send a sample of 5 cards to DSX for evaluation.

Securakey Barium Ferrite Readers

The Securakey SK-028, SK-034, and SK-038 are the Barium Ferrite Readers that DSX supports. The SK-028 is the Rusco Barium Ferrite Replacement Reader. The SK-034 is the Securakey Card Reader that reads Securakey Cards. The SK-038 is the Cardkey Barium Ferrite Replacement Reader. The Securakey readers connect to the DSX panels directly.

The PCSC reader requires interface module. The readers and module should be tested to verify operation. It should be noted that DSX does not sell, support, or provide additional cards or readers for the brands listed on this page.

SK-028 / SK-034 / SK-038 Securakey Reader

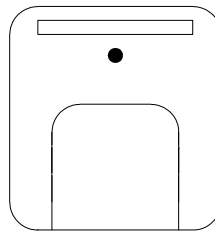

Description

All Securakey Key Touch Plate Readers follow the same wiring scheme. There are currently 3 different Securakey Key Readers, the SK-028, 034, and 038. The SK-028 is used to read existing Rusco barium ferrite cards. The SK-034 is used to read Securakey Key barium ferrite cards. The SK-038 is used to read existing Cardkey barium ferrite cards. All 3 readers wire to the panel in the same manner and transmit the card data in a Wiegand format.

LED Operation

Red = Door is Secure (Locked)
Red Off = Door is Open (Unlocked)
Red Flashing = Reader is in Lockout Mode.
Two to Red Flashes = Access Denied

Lockout Mode

Lockout occurs when the number of consecutive denials allowed at a reader has been exceeded. The reader will remain in the lockout mode for 30 seconds. During the Lockout, the reader LEDs should switch rapidly from red to green for 30 seconds and it will not read ANY cards whatsoever. The number of consecutive denials allowed at a reader is determined under Location in the Database portion of the WinDSX software.

Access Denied

If an Access Denied indicator is desired at the reader, a jumper may be placed between LED 2 and LED 3 of the DSX-1022 panel. LED 3 provides 2 quick pulses when a card is denied access. By placing a jumper between LED outputs 2 and 3, the card reader LED will give two Green to Red flashes when a card is denied access.

Retrofits

The SK-028 Rusco compatible reader provides a replacement for the Rusco barium ferrite reader. It will connect directly to the DSX-1022 panel and read the existing Rusco Cards.

The SK-038 is used in a DSX system to read Cardkey barium ferrite cards. The Cardkey barium ferrite insert reader can be used with the DSX system if the Cardkey insert reader Wiegand interface and the DSX-CKI module are both used. Otherwise, the SK-038 must be used to read the Cardkey Barium Ferrite Cards and is connected directly to the DSX-1022 Panel.

Securakey Key Touch Plate Reader Connected to a DSX-1022

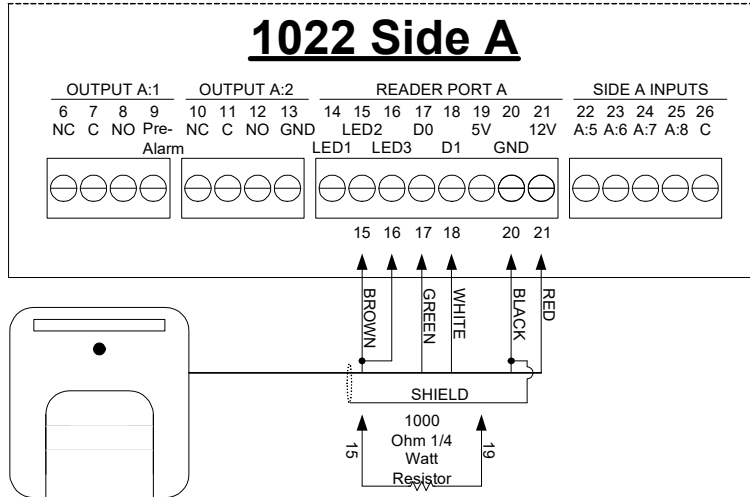

Device Types

The Device Type for the SK-028 Rusco Replacement Reader is RT.
 The Device Type for the SK-034 Securakey Key Reader is 32.
 The Device Type for the SK-038 Cardkey Replacement Reader is CT.

LED

The resistor shown in the above drawing is necessary to activate the Red LED on the reader. If the resistor is not in place, the reader LED will be Off when the door is Secure. The resistor does not affect the reader performance.

Grounding

The Securakey readers must have the Green Chassis Ground Screw that is attached to the mounting plate connected to earth ground for proper operation and protection from static electricity problems.

Time Keeping Systems TKS-110 Bar Code Reader

Below is one of the bar code readers that will work with the DSX System. The TKS-110 is the bar code reader that DSX sells and supports. The TKS-110 will read almost any existing bar code including Kronos. Search the Help Screen (F1) for Device Types under Device in the Database Program to determine the proper device type for the Bar Code you desire to use.

It is recommended to use 18 AWG wire with this reader since it is 5V powered and voltage drop can be critical to proper operation. If necessary, use a 12V regulator at the reader. Connect the 12V power of the panel to the regulator and the 5V output of the regulator to the reader. This will keep the 5V power constant and compensate for a long wire run.

Note /// New TKS-110 Readers that are smaller than the original and are potted and sealed are 12V powered. There is also an adapter plate that will allow a new unit to mount in the place of the older, larger reader and to a single gang electrical box.

TKS-110

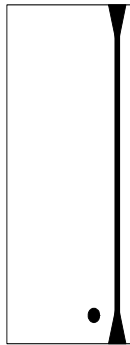

Description

TKS-110 Bar Code readers will connect directly to the DSX-1022 panel and will work with both new and existing bar code access cards. The reader is compatible with the following bar code symbologies: Code 39, Interleaved 2 of 5, UPC/EAN, Codabar, Code 93, Code 11, Code 128, and MSI. The TKS-110 is auto-discriminating and reads in both directions.

LED Operation

- Red On = Door is Secure (Locked)
- Green On = Door is Open (Unlocked)
- Red/Green Flashing = Reader is in Lockout Mode.
- Red /Green Flashing twice = Access Denied

Lockout Mode

Lockout occurs when the number of consecutive denials allowed at a reader has been exceeded. The reader will remain in the lockout mode for 30 seconds. During the Lockout the reader LEDs should switch rapidly from red to green for 30 seconds and it will not read ANY cards whatsoever. The number of consecutive denials allowed at a reader is determined under Location in the Database portion of the WinDSX software.

Access Denied

If an Access Denied indicator is desired at the reader, a jumper may be placed between LEDs 2 and 3 of the DSX-1022 panel. LED 3 provides 2 quick pulses when a card is denied access. By placing a jumper between LED outputs 2 and 3, the card reader LED will give two Red to Green flashes when a card is denied access.

IC-201 Pre-Printed Bar Code Labels

When using the IC-201 Pre-printed bar code labels with the TKS-110 the reader must be set in the Wiegand output mode. To do this, do not connect the Orange, Blue, or Yellow wires. The Device Type to use with the TKS-110 in the Wiegand mode and the IC-201 Bar Codes is WE.

Bar Code Positioning

The Bar Code should be located on the card according to the specifications below.

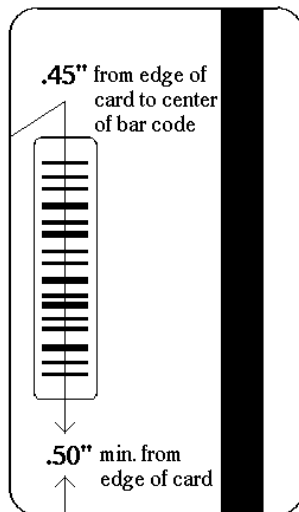

TKS-110 Bar Code Reader in Clock and Data Mode to a DSX-1022

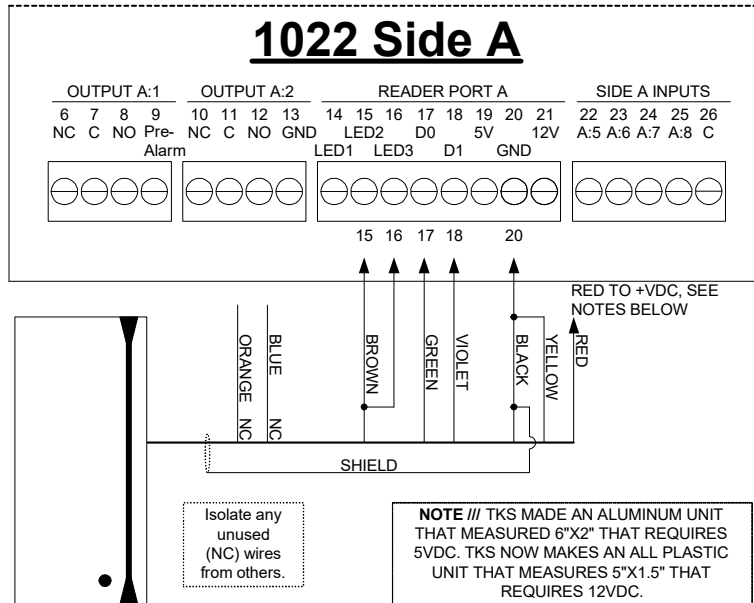

Wiegand Mode

To Put the TKS-110 in a Wiegand Output Mode, Do Not connect the Yellow, Orange, or Blue wires. Isolate these wires individually. For proper 26-bit Wiegand mode the barcode must be formatted with a 3-digit facility code and a 5-digit card number that is 65534 and lower in range.

Device Types

The above diagram shows the proper connection for the TKS-110 bar code reader when used in the Clock and Data mode. The device type used for this reader will vary depending on the card it is being used with. If you wish to use this reader with an existing card base, please contact DSX for compatibility testing and proper Device Type selection.

DSX Keypads

Keypads may be used as either a primary mechanism to enter a code number for door access or as the secondary method of using a card and a PIN for entry. With the PIN options turned on in WinDSX, a valid card must be presented to a card reader followed by the entry of a 4-to-7-digit PIN for access. Other options can direct WinDSX to allow duplicate PIN numbers to be allowed. In some cases, the Reader and Keypad can connect to the same side of a DSX panel. In some cases, a manufacturer has a product line that includes a reader/keypad combination that mounts to one single gang box. In other cases, it requires two single gang boxes for the two pieces of hardware even though they may still connect to the same reader port. Use caution when connecting and reference this manual for additional connection drawings regarding known compatibilities. If you are unsure, call DSX Technical Support for assistance.

The DS-12 is an Indoor/Outdoor keypad with a Stainless-Steel finish. The older DS-12 has a BCD output that connects to the first four inputs on a DSX-1032 and is no longer supported. The new DS-12 has a Wiegand Burst Output that connects to the card reader port. The following diagrams show how to connect the DS-12 keypads to the DSX-1022.

Note /// The DS-12 keypads that have a BCD output, which can be identified by their data connection to inputs 1-4 on the controller, are no longer compatible with WinDSX Software. Those keypads must have the DS400IB – BCD to Wiegand 8bit Burst Module added, to convert their output. The module can be placed at the controller.

DS-12 Indoor/Outdoor Keypad

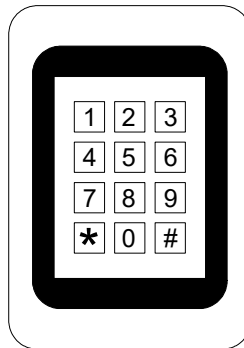

Description

The DS-12 Keypad provides all key information as a Wiegand Burst Output to the DSX-1022. This Wiegand Burst Output of the DS-12-8W has no code limitations. This keypad can be used standalone or added to some readers for Card + PIN operation. Four-, five-, six-, or 7-digit codes are possible with full range of all number sequences.

LED Operation

Green	Red	
On	Off	= Door is Open (Unlocked)
Green	Red	
Off	On	= Door is Secure (Locked)
Green	Red	
On	On	= Door is Secure (Locked) and keypad data entry is occurring.
Green	Red	
2 Flashes	On	= Invalid code was entered, Door is Secure (Locked)
Green	Red	
Flash	Flash	= Keypad is in Lockout Mode.

The Green LED will turn on with the first key depression and turn off when the panel has recognized the proper number of digits for a PIN. If the PIN is 5 digits long, the Green LED would turn on when the first number is pressed and turn Off when the fifth number is pressed. With the same example, if only 4 digits are entered, the Green LED will turn Off 5 seconds after the last digit is pressed. When the Green LED is Off the PIN can be entered or re-entered. If the door is secure and the wrong code is entered will cause the Green LED to flash twice.

Lockout Mode

Lockout occurs when the number of consecutive denials allowed at a reader has been exceeded. The reader will remain in the lockout mode for 30 seconds. During the Lockout, the reader LEDs should switch rapidly from red to green for 30 seconds and it will not accept ANY keypresses whatsoever. The number of consecutive denials allowed at a reader is determined under Location in the Database portion of the WinDSX software.

Power

The DS-12 is 5 – 12 V powered. Jumper Pins on the back make the selection of 5 or 12V. With the jumper on one of the two pins the keypad is 12V. With the jumper on both pins the keypad is 5V.

26-bit Versions DS-12-26 & DS-12-SL26 (use for special applications only)

The DS-12 26bit output keypad has a single LED control line (brown wire) which typically connects to LED # 2. This version of the DS-12 has a code limitation of 65534. Numbers higher than this will not work. This version can be added to some readers for Card or PIN operation. Once a code is entered you must press the #.

ThinLine Keypad Illumination

The 2X6 thinline keypad, DS-12-SL, has two LEDs that can be used for illumination and draw an additional 20ma. To enable cut the wire jumper next to the wiring connector.

DS-12 Keypad with Wiegand Output connected to a DSX-1022

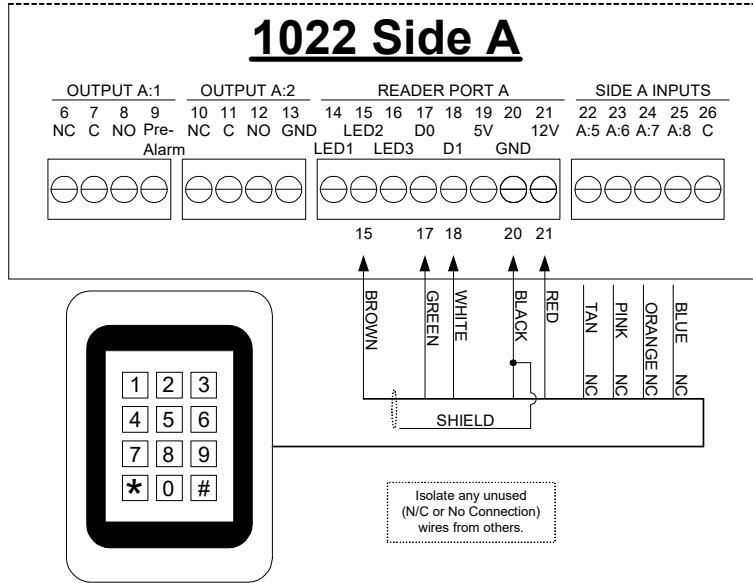

Power

The DS-12 is 5 – 12 V powered. Jumper Pins on the back make the selection of 5 or 12V. With the jumper on one of the two pins the keypad is 12V. With the jumper on both pins the keypad is 5V.

Aux. Output

The Blue wire is an open collector output that sinks 250 ma. It provides a 30-second negative when any key is pressed.

LED Control

With the Orange wire not connected, the brown wire controls the Green LED, and the yellow wire controls the Red LED. When an LED line is pulled low the corresponding LED turns on. With the Orange wire connected to ground the Brown line controls both LEDs. When the Brown line is pulled low Green is on and Red is off. With the Brown line floating the Red LED is on and Green is off.

Device Types

The DS-12 Keypad is an indoor/outdoor keypad with a single gang configuration and a Stainless-Steel finish. The Device Type for the DS-12 with Wiegand output is DK. All Wiegand Burst Output Keypads use Device Type DK.

DS-12 Keypad with Clock and Data Output connected to a DSX-1022

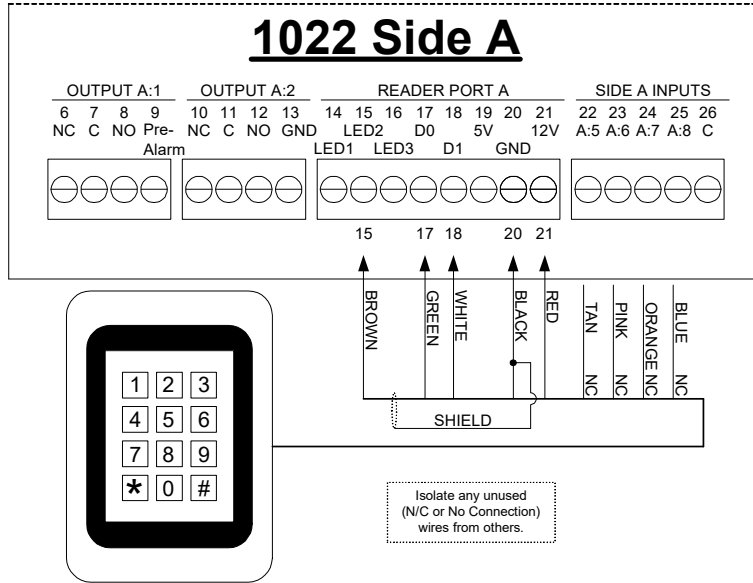

Power

The DS-12 is 5 – 12 V powered. Jumper Pins on the back make the selection of 5 or 12V. With the jumper on one of the two pins the keypad is 12V. With the jumper on both pins the keypad is 5V.

Device Types

The DS-12 Keypad is an indoor/outdoor keypad with a single gang configuration and a Stainless-Steel finish. The Device Type for the DS-12 with Clock and Data Output varies depending on what card reader and card format it is to be used in conjunction with. This keypad is typically used in conjunction with the TKS-110 barcode reader or any magstripe reader with a clock and data output.

DSX-DP232 and DSX-DP485 Surge Suppression Modules

DSX offers two data line surge suppression modules for use in applications where transient voltages from lightning or RF may cause damage to data communication circuits. The modules offered are the DSX-DP485 and the DSX-DP232.

The DSX-DP485 is designed to protect any 5-volt data communications circuit. The DP485 would be used in the DSX system to protect the RS-485 data communications. The DSX-DP232 is designed to protect any 12-volt data communication circuit. The DP232 would be used in the DSX system to protect the RS-232 data communications.

These data line protection modules offer 3 stages of surge suppression. Each line has its own voltage divider, gas discharge tube, and transzorb. Both modules appear as a 25-ohm load in series with the communications line.

DSX highly recommends the use of these modules anytime the data communications is exposed to transient voltages. An example would be the RS-485 communications between controllers leaving building 1 and going into an underground conduit and entering building 2. You should place a DP485 module in each building. The first would be placed in series with the RS-485 wires after all controllers in building number 1. The second would be placed in series with the RS-485 wires before they connect to any controllers in building 2. By placing a suppression module at both ends of the circuit, you will protect the data communication circuits of the controllers in both buildings from transient voltages.

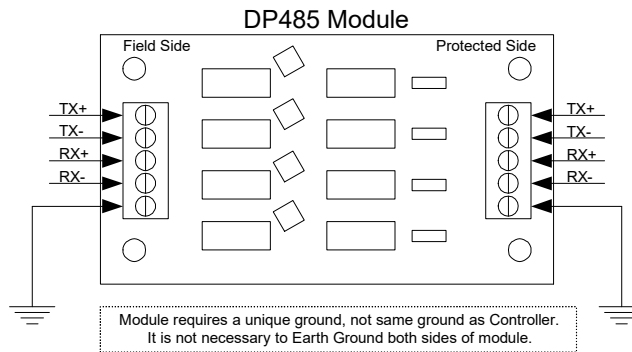

Note /// DSX DP-232 and DP-485 Modules are placed at both ends of the underground or overhead cable, isolating this exposed wiring from the controllers or equipment at both ends.

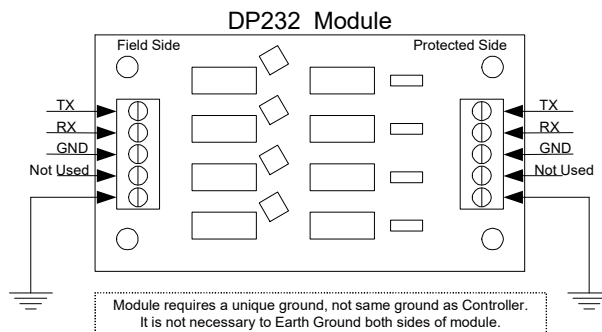

Field Test Procedures

Power-UP Check

1. Follow instructions in DSX installation manual for proper dipswitch settings and wiring connections.
2. Connect 16.5 VAC transformer to terminals 1 and 2 of the DSX-1022 controller.
 - A. LED above or next to these terminals should light indicating power on.
 - B. Power LED on the top right corner of the 1022 should light and the bottom Heartbeat LED should blink indicating the processor is operating.
3. Master Controller
 - A. LEDs at terminals 48 and 50 of the controller should blink to indicate communications with the PC.
 - B. Download LED should light to indicate a download in progress to the Sub controllers.
 - C. If there are Sub controllers, the Poll LED will light to indicate polling of the Sub controllers.
4. Sub Controller(s)
 - A. LEDs at terminals 56 and 58 of the controller will light to indicate communication with the Master controller.
 - B. Download LED will light to indicate a download in progress from the Master.
 - C. Poll LED will light to indicate the Master controller is polling the Sub.
5. Upon Completion of Download
 - A. All output indicator LEDs should be in the desired state as defined by the database.
 - B. Input indicator LEDs will be lit for all inputs that have the E.O.L. resistor connected.

Reader Function Check

1. Go to a secure reader-controlled door
 - A. The indicator LED on the reader should be Red to indicate a secure state and the door lock should be energized.
2. Use a valid card at the reader
 - A. The indicator LED on the reader should turn Green to indicate an open state and the door lock should be de-energized.
 - B. An Access Granted message should be displayed at the PC within the Workstation Event Window.
3. Use an invalid card in the reader
 - A. The indicator LED should flash twice but remain Red to indicate a secure state and the door lock should remain locked.
 - B. An Access Denied message should be displayed at the PC.

Note /// If the controller fails any of these checks, refer to trouble shooting section.

Trouble Shooting

Cannot Communicate with Master from PC in Direct Connect Mode.

This is a common problem when setting up a system due to the many parameters involved in establishing the communications from the PC to the Master controller. Go through the following checklist in detail. Even if you think you have already checked an item, check it again.

1. Verify that the dip switch settings of the Master controller match the location address that you have defined in the database. If you have a direct connect Master that is to be location 1, then only dip switches 1 and 8 should be On. With all power disconnected to the controller, physically move each switch back and forth to make sure it is not set halfway between the on and off position then power up the controller.
2. Verify that the dipswitches on the Master are set according to the On and Off markings on the circuit board, not the open and close markings of the dip switch.
3. Check the location definition in the PC, make sure the connect type is D for Direct and that at least devices 0&1 are defined in Database of the software. (The number of devices should always be two times the number of controllers.)
4. Check the setup program under Comm Ports, make sure that a serial port has been defined for the direct connect. The port parameters are 9600, 8, 1, N, and D.
5. Make sure there are no other programs running on the PC that are trying to use the same serial port as the DSX system.
6. Use an ohm meter to verify the Communications is in accordance with the installation manual wiring connections for a direct connect Master. Make the necessary connections from the PC to the Master as a direct connect system. These connections are shown on page 28 of this manual. Also verify that the mode dip switch(es) on the Master Controller is set with 8 On (Master Direct Connect).
7. Using Windows Explorer find the WinDSX directory and locate the kb2cw.exe file and double click on it. Make sure that CS, DB and WS are not running before running kb2cw
8. Select Comm Port from the menu at the top and set the port number to match the port used. Then set the Baud Rate to 9600, Word to 8, Stop Bits 1, and Parity to None and click on OK.

The program should return a message that displays the port, baud, data length, and stop bit settings and show a single line flashing cursor. If you receive a message that says: "Port could not be initialized", there is a hardware problem with the PC that must be corrected.

9. Press the Enter key three times. You should see a DSX> prompt returned to the screen. If you do not get this prompt continue with the trouble shooting section of this manual. If you receive the DSX> prompt, the comm port has been verified as good and you have communicated with the firmware of the Master Controller.

Verify that another comm port is not the needed port. Define next Comm port and test with it.

If the cursor is just sitting and flashing, we can continue testing the serial port and wiring. When running the KB2CW program, each time a key is pressed on the keyboard, it is transmitted out the serial port. Any data that is received by the serial port is displayed on the screen. This provides a simple method of testing the serial port by connecting the transmit signal to the receive input. This type of a connection will cause any character that is typed on the keyboard to be displayed on the screen

thus, testing the serial ports transmit and receive capabilities. On a 25-pin serial port pin 2 is transmit and pin 3 is receive. On a 9-pin serial port pin 3 is transmit and pin 2 is receive.

10. Connect pin 2 to pin 3 right at the computer and then type on the keyboard. If the characters typed are displayed on the screen, the serial port is functioning. If the characters are not displayed, either the serial port is bad, or you are connected to the wrong serial port. Try moving the connector to the other serial port and typing in characters.

11. If the serial port test is passed, re-connect the wires at the PC Comm Port that go to the DSX Master controller. Disconnect the RS-232 wires from the Master controller and twist together the wires connected to pins 2 and 3 on the PC. Return to the computer and while running the KB2CW program, type any letter key on the keyboard and see if it is displayed on the screen. If not, then you have an open or grounded wire between the computer and the Master controller.

12. If the characters are displayed on the screen, return to the Master controller, and connect the 3rd wire from the ground terminal that is connected to pin 5 on a DB-9, or pin 7 on a DB-25 serial port, to the other two wires previously connected. Return to the PC, while running the KB2CW program, type any letter key on the keyboard and see if it is displayed on the screen. If it is displayed, then you have an open ground wire between the PC and the Master controller.

13. If the characters are not displayed when the above test is run, then the serial port and the wiring are both correct. Use a voltmeter and measure between ground and the transmit and receive wires. The wire that has a negative voltage between -8- and -12-volts DC is the transmit from the computer and should be connected to the RS-232 receive of the Master controller. The other wire should not measure any voltage and should be connected to the RS-232 transmit of the Master. The ground wire of the PC should be connected to ground of the Master.

Note /// If trying to perform a loopback test from the Serial Port through a DSX-MCI module, remove the RS-485 wires from the controller and connect TX+ to RX+ and TX- to RX-. This provides a means of testing the RS-485 output of the MCI module.

Device Communication Losses / Missed Polls.

Device Communication Fails and many missed polls can be seen from the 1040 Series Controllers when they are added into existing 1030 Series systems. This occurs when the RS-485 Transmit and Receive negatives have been crossed between Controllers. The problem could be undetected in existing 1030 Series systems until the 1040 Series equipment is added. Finding the problem requires a voltmeter on a low AC Voltage scale and measuring voltage at specific places.

Examples for Master to Sub wired correctly:

1. Master RS485 IN, measure between tx+ and tx- = should be 2.5 – 3.0 Volts AC
2. Master RS485 IN, measure between rx+ and rx- = should be 2.5 – 3.0 Volts AC
3. Sub RS485 IN, measure between tx+ and tx- = should be 2.5 – 3.0 Volts AC
4. Sub RS485 IN, measure between rx+ and rx- = should be 2.5 – 3.0 Volts AC

Examples for Sub to Sub with correctly connected RS-485 communications.

1. 1st Sub RS485 IN, measure between tx+ and tx- = should be 1.5 – 2.5 Volts AC
2. 1st Sub RS485 IN, measure between rx+ and rx- = should be 2.5 – 3.0 Volts AC
3. 1st Sub RS485 OUT, measure between tx+ and tx- = should be 1.5 – 2.5 Volts AC
4. 1st Sub RS485 OUT, measure between rx+ and rx- = should be 2.5 – 3.0 Volts AC
5. 2nd Sub RS485 IN, measure between tx+ and tx- = should be 1.5 – 2.5 Volts AC
6. 2nd Sub RS485 IN, measure between rx+ and rx- = should be 2.5 – 3.0 Volts AC
7. 2nd Sub RS485 OUT, measure between tx+ and tx- = should be 1.5 – 2.5 Volts AC
8. 2nd Sub RS485 OUT, measure between rx+ and rx- = should be 2.5 – 3.0 Volts AC

Examples for Sub to Sub with negatives crossed between Sub 1 and Sub 2.

1. 1st Sub RS485 IN, measure between tx+ and tx- = should be 1.5 – 2.5 Volts AC
 2. 1st Sub RS485 IN, measure between rx+ and rx- = should be 2.5 – 3.0 Volts AC
 3. 1st Sub RS485 OUT, measure between tx+ and tx- = would be less than 1 Volt AC
 4. 1st Sub RS485 OUT, measure between rx+ and rx- = would be 1.0 – 1.5 Volts AC
- Negatives are crossed here.
5. 2nd Sub RS485 IN, measure between tx+ and tx- = would be less than 1 Volts AC
 6. 2nd Sub RS485 IN, measure between rx+ and rx- = would be 1.0 to 1.5 Volts AC
 7. 2nd Sub RS485 OUT, measure between tx+ and tx- = should be 1.5 – 2.5 Volts AC
 8. 2nd Sub RS485 OUT, measure between rx+ and rx- = should be 2.5 – 3.0 Volts AC

No Master to Sub Communications.

1. Verify the address dip-switch settings of the Sub controller. While the controller has been de-energized physically move each switch back and forth to make sure it is not set halfway between the on and off position then re-power the controller.
2. Check to make sure that the communications wiring is connected according to the schematics shown for Master to Sub communications. The transmit of the Master should connect to the receive of the first Sub. The receive of the Master should connect to the transmit of the first Sub. After the first Sub, the RS-485 wiring should connect transmit to transmit and receive to receive. The 485 polarity is always "+" to "+" and "-" to "-".
3. Be sure that all controllers are earth grounded. If controllers are not properly grounded, ground current loops can be formed over the communication wires and interfere with controller communications.
4. Check within Database Location and make sure within Device that we have enough devices listed for the number of controllers. The number of devices listed should be the number of controllers times 2. So, if you have 6 DSX controllers in the job, the number of devices shown should be set 12. Each DSX controller counts as 2 devices.
5. Check communication wires with an ohmmeter for continuity and ground faults.

Card Reader Error Messages

Receiving Bad Card Read Messages from Card Reader.

Example (Bad Card Read **26**)

This message means that the DSX-1022 controller is not seeing the correct number of data bits being transmitted from the reader for the reader type that is programmed into the system. The example provided implies that the card reader read 26 bits from the card and the "Device Type" is not set to a 26bit device type. Verify that the device type selected matches the reader and card combination in use. Check power at the reader. Check to make sure the data 1 and data 0 reader communication lines are connected properly. Measure the voltage on data 1 and data 0 of both sides of the controller. Both data 1 and data 0 should be above 3.7VDC on both sides of the controller. If voltage is low or not present on a reader data line, remove all field wiring from that reader port and test again if the voltage is present without the wire connected the field wiring is shorted or grounded. If the voltage is not present when the wire is disconnected the reader port has failed. Make sure that the field-wiring shield is connected to ground at the controller only.

Receiving Parity Error Messages from the Card Reader.

This message means that the controller is receiving the proper number of data bits from the reader, but the parity check is not correct. Check under the "Device, Options" definition and make sure the "Reverse Card Data" field is set correctly for your reader. The only time this field should be checked is when a Sensor Wiegand insertion card (not key) reader is connected. Even then, some cards bought from other manufacturers are built so that the "Reverse Card Data" field may need to be turned off even when you are using a Sensor Wiegand card insertion reader. Check to make sure that data 1 and data 0 are connected properly. Make sure that the card is being run through the reader in the proper direction. Make sure that the device type matches the cards and readers in use.

No Message from Reader when Card is Used.

Verify voltages on data 0 and data 1 as described in “Receiving Bad Card Read Messages from Card Reader” section above. Verify that “Display Bad Card Read Events” is enabled in the “Location, Y/N Options”. Verify the Device has a timezone assigned to it. Verify that within Workstation the reader is set to TZ by right clicking on the device.

Controller Resets when the Lock is De-Energized.

Either there is no MOV installed at the lock or the MOV is not functioning properly. Remove the wire connected to the positive side of the lock from the controller and physically touch the wire to the lock power source. Now pull the wire away from the power source. If you see a spark when the lock wire is removed from the power source, then your MOV is not functioning or is the wrong voltage. Replace the MOV at the lock to correct the problem. If the problem persists, place an MOV in parallel with the lock wire across the relay output of the DSX controller. If your lock power is connected to the NC side of the relay, connect the MOV across the C and NC terminals of the controller. If your lock power is connected to the NO side of the relay, connect the MOV across the C and NO terminals of the controller. Also make sure that the DSX controller is properly grounded. If the problem still exists after MOV and grounding have been verified, an isolation relay may have to be used to prevent the lock surge from affecting the DSX controller.

Output 1 will not Secure.

Make sure that the exit request input number 8 is not in an abnormal state. When input 8 is used as the exit request, the input must be normal hence the status LED must be On before output 1 will secure. The Input must see the 1K ohm resistor to be normal. Make sure the output relay number 1 for the device in question has an active time zone assigned to it. Make sure the output has not been programmed for Fail Secure under the output definition.

Output 1 only Unlocks for 1 Second.

The “Door Open Detect Relock” feature has been enabled under the Device definition and the door contact input, Input 7, is in a constant abnormal state. As soon as the door is unlocked, the controller sees that the door contact is abnormal and immediately relocks the door. Correct the problem with input seven, the door position switch, or disable the Door Open Detect Relock feature.

Output will not Respond to Linking Event.

Make sure that the relay to be linked is in the opposite state of the programmed linking state before the link takes place. That is, if you wish a relay to be linked open, make sure that it is secure before the link takes place. Also verify the linking state is programmed correctly for the output. To program an input to output link, enable in “Location”, define the output relay, put it into a “Linking Group”, assign the “Linking Group” to the input. To program a code to output link, enable in “Location”, define the output relay or input to link to put it into a “Linking Group”, create a “Linking Level” with the “Linking Group”, assign the “Linking Level” to the access code with an appropriate access level (not the Master Access Level). Verify that the relay is not already linked to.

Output 1 will not Respond to Exit Request.

Be sure that the Use Inputs 7 and 8 question under the device definition is selected with a checkmark. Also make sure that the relay output is currently in the secure (Energized) state. You can tell if the output is secure by viewing it in “Workstation” or by looking at the LED located nearest the terminal strip for the output. If the LED is on, the output is secure. If the LED is off, the output is open. An output must be in the secure state before the exit request will open it.

No Battery Charging Voltage.

The battery fuse is blown. Replace the fuse marked BATT with the appropriate fuse. See the section on Fuses in this manual.

No 12 VDC Power Output.

The 12VDC fuse is blown. Measure the circuit for a short or ground and then replace the fuse.

Input Will Not Set Up.

Check field wiring with an ohmmeter for shorts, opens, or grounds. Remove field wiring from the controller and place a 1K-ohm resistor directly across the input. If the input still does not setup, replace the controller.

Routine Maintenance

1. Back-up battery should be replaced if the Low Battery LED lights and a Low Battery message is sent to the PC.
2. Continuity to Earth Ground should be checked periodically. (see Grounding Connections in the manual)
3. Fuses should be replaced if the corresponding indicator LED is lit on the controller or if the fuse measures voltage from one end to the other while installed. (see Replacement Fuse Specifications in the manual)

Conditions Which May Cause Undesired Operation

1. Failure to replace batteries, which have generated a Low Battery report.
2. Failure to replace blown fuses with proper fuse. See Replacement Fuse Specifications in this manual.
3. Failure to provide a good Earth Ground to the DSX-1022 controller. See Battery and Ground Connections in this manual.
4. Failure to follow recommended cabling specifications. See Cable Specifications in this manual.
5. Failure to provide proper power. See AC Power Connections in this manual.
6. Failure to follow proper addressing conventions for Master and Sub controllers. See Master / Sub Dip-switch Settings in this manual.
7. Failure to follow communication / reader hook-up instructions. See appropriate section in this manual.

This page was intentionally left blank.

®



The Security Professionals' First Choice

DSX Access Systems, Inc. 10731 Rockwall Road Dallas, Texas 75238
Accounting, Sales, Shipping and Technical Support
800-346-5288 or 214-553-6140 www.dsxinc.com