



DSX Access Systems, Inc.

L85 Integrated Locksets

The L85 software provides a method to integrate wired and wireless locksets into a DSX Access Control System. The L85 software leverages its Virtual Hardware capabilities to accommodate non-controller based locks and readers. Hundreds or even thousands of these devices can be installed through multiple deployments of the L85 software. Non-controller based locksets are a powerful addition to the DSX Access Control System product line. The L85 software provides powerful flexibility with a fully integrated solution of both hardwired and wireless readers and locks.

Locksets with integrated readers are well suited for facilities that require supervision and online management of a high number of low security doors. Applications such as college dorms or any door where traditional hardware is almost impossible to install will realize a significant cost savings by utilizing the L85 software to manage integrated locksets.

The L85 software takes the place of Slave Controllers in a DSX system and communicates back to the Comm Server via a Master Controller or through the PC Master software. The L85 software can communicate with up to 126 locksets and maps the locksets to virtual devices, inputs, and outputs defined in the WinDSX program. There is little difference in the WinDSX program between the hardwired and wireless devices. Most features in WinDSX are also available to the non-controller based locksets connected through the L85 software.

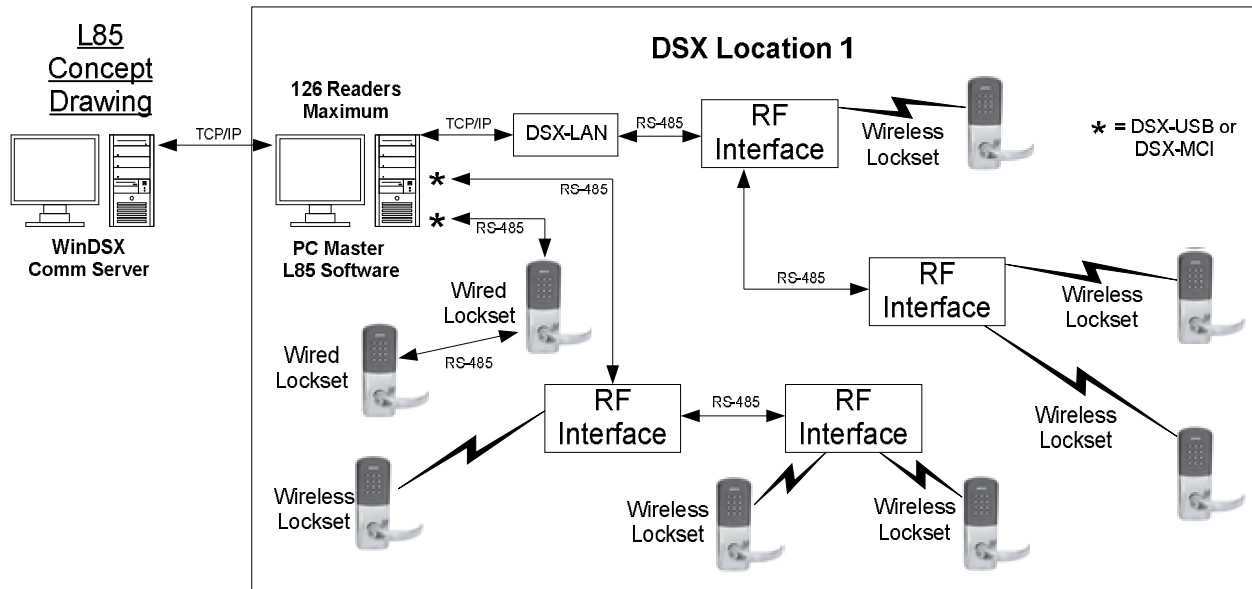

L85 and Schlage Locksets

Wireless and Hardwired Locksets come in an array of chassis types, lever styles and finishes. They are complete with everything needed at the door with no or minimal wiring. Included is the electrified lock, credential reader, request to exit, door position switch, tamper guard, and battery monitor. Wireless units operate on 4 AA batteries. Any of these integrated locksets can be ordered with a magnetic swipe reader, proximity reader, smart card reader, or multi-tech reader. A keypad can be used by itself or added to any of these readers for Card + PIN authentication or PIN only authentication.

There are three basic system architectures used to integrate the Schlage locksets into WinDSX;

- 1) No DSX controllers, only PC Master and L85 software controlling Schlage Locksets
- 2) Mixture of DSX controllers and L85 software controlling Schlage Locksets
- 3) Schlage Locksets connected directly to DSX controllers.

Mixtures of the 3 architectures could be used simultaneously within the same system. Each Schlage Lockset maps to a DSX Device address within the WinDSX software. A single instance of the L85 software can accommodate 126 Locksets. Through multiple deployments of L85 software, thousands of these Locksets can be controlled by a single DSX System.

When the L85 software is used with the Schlage locksets all access control decisions are made by the L85 software. The Schlage Locksets can operate in an offline cache mode if the communications with the L85 software is interrupted. During the cache mode each Locksets will grant access to the last 125 card holders that were granted access at that particular Lockset.

In the diagram below you will notice a Comm Server that communicates TCP/IP to a computer running PC Master and L85 software. PC Master performs the communication duties of a DSX-Master Controller and could communicate with DSX Slave Controllers as well as the L85 software. The L85 program operates as virtual DSX Slave Controllers and as an interface to the Schlage Locksets.

The L85 software can use TCP/IP, USB, and RS-232 serial ports to communicate with the PIM400-485 and the AD-300 Wired Locksets. The Schlage PIM400-485 module provides the RF link to the AD-400 Locksets. DSX-LAN modules can be used to communicate to the PIM400-485s over the network and the DSX-USB modules can be used to hardwire the AD-300 locks and/or PIM400-485 modules through a USB port.

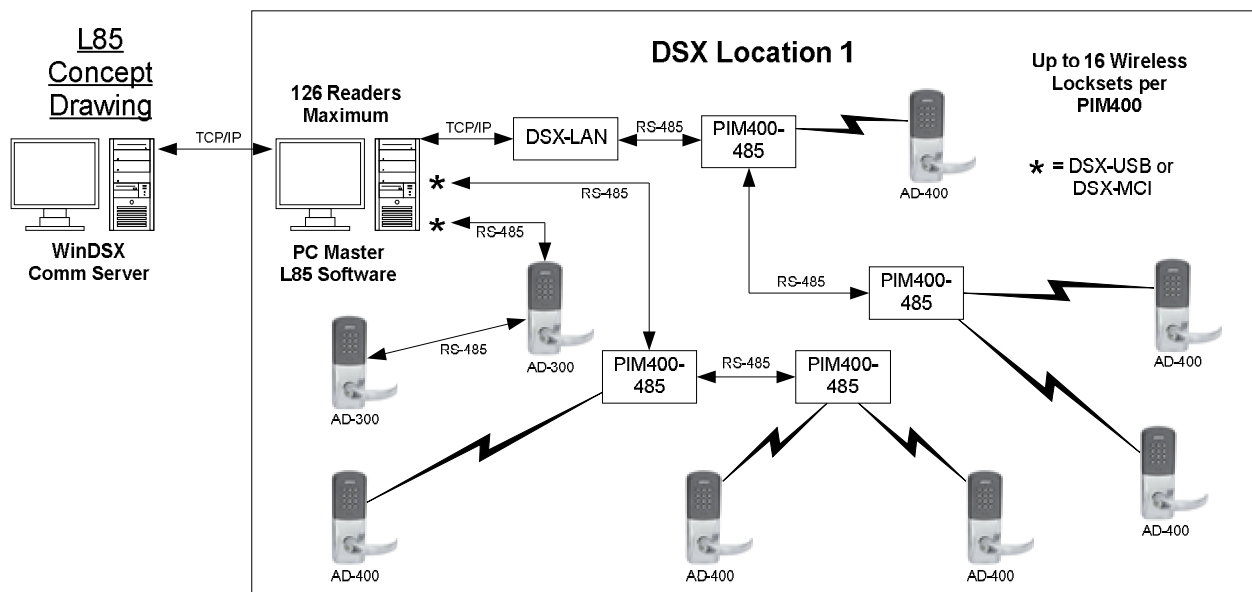

L85 and Schlage Locksets

The third system architecture does not use the L85 software at all. Instead it uses DSX Controllers outfitted with PIM400-TD2s. The PIM400-TD2 provides a hardwire interface to the DSX controller and a wireless interface to the AD-400 Lockset. The PIM400-TD2 hardwires to the Controller and supervises two wireless Locksets. This is great for applications whose scope does not warrant the deployment of the L85 software. The Controller makes all of the decisions and the PIM400-TD2 supervises and communicates with the two AD-400 wireless Locksets.

In this diagram the Comm Server communicates over the LAN to the Master Controller by way of a DSX-LAN module. This diagram shows two of the Controllers using PIM400-TD2s to interface to the AD-400 Wireless Locksets. It also depicts one Controller as having traditional wired card readers.

DSX Controllers, readers, and locks can be mixed in any of these different applications with L85 Integrated Locksets.

Any of these system architectures can be used simultaneously within the same WinDSX System.

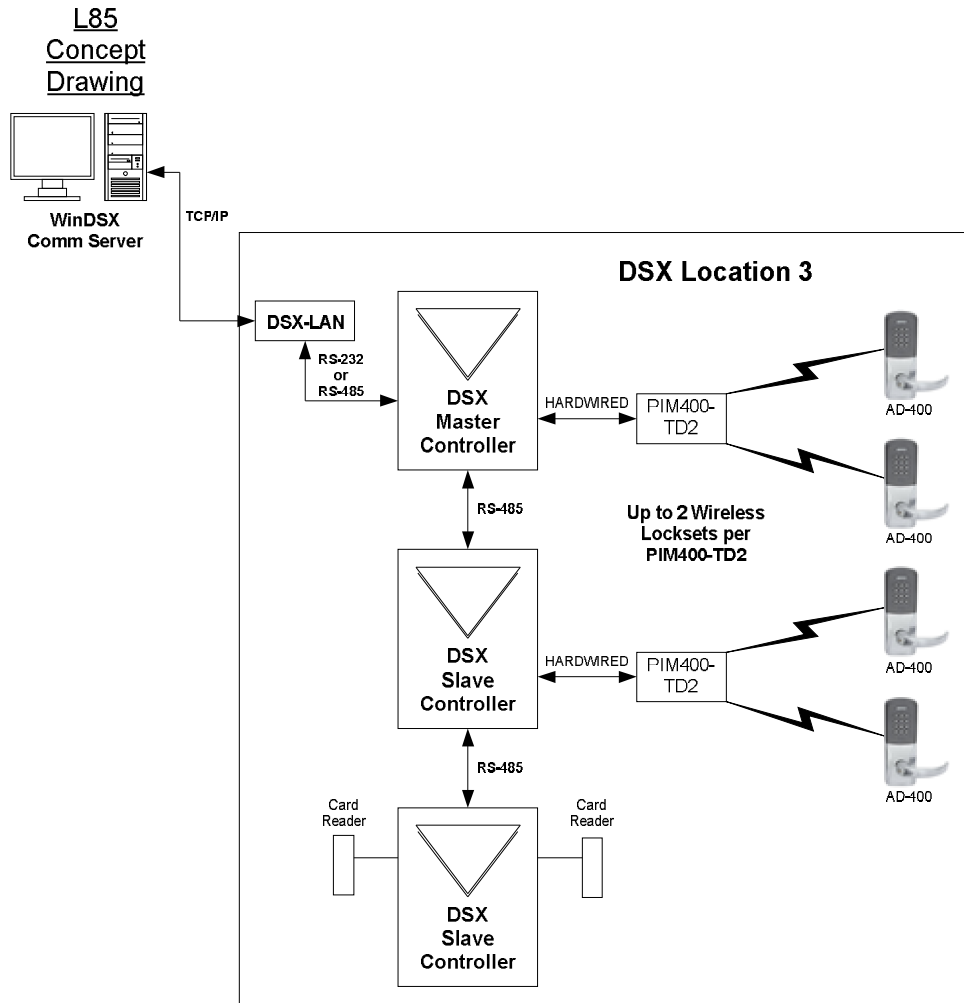

L85 and Schlage Locksets

Components:

WinDSX – Access Control Software (PACS)

PIM400-485 – Communicates with L85 over RS-485 or LAN. Uses RF to communicate with up to 16 wireless Locksets.

PIM400-TD2 – Controller dependant interface for 2 Wireless Locksets.

RS-485 – Form of hardwired communications using two twisted pair cable.

AD-300 – Wired Lockset communicates over an RS-485 connection to L85. Only operates with L85.

AD-400 – Wireless Lockset communicates to PIM400-485s and PIM400-TD2s

Comm Server – The DSX Communications server that is responsible for all communications to and from any DSX Location.

L85 Software – The program that provides the integration to the Schlage Locksets.

PC Master – Acts as a virtual Master controller that bridges communication between the WinDSX Comm Server and the L85 software and/or any DSX Controllers.

DSX-1035 Quadraplexor – RS-485 Star Communications interface. Accepts RS-485 in and provides 4 - RS-485 outputs for Controller to Controller Communications. It also has an RS-232 output that could be connected to a Serial Port of the L85 computer.

DSX-USB – USB to RS-485/232 converter. Will provide a 4-wire RS-485 communications output from a USB port on the L85 computer.

DSX-LAN – Ethernet to RS-485 converter can be used to provide a 4-wire RS-485 output from a LAN connection.

Schlage Lockset Facts:

- Expected battery life is up to 2 years based on 100 operations per day, 10 minute heart beat, 10 second wakeup. 1 operation = card read, unlock door, open door, close door, re-lock door, request to exit active, open door, request exit inactive, and close door.
- There can be up to sixteen PIM400-485s / per Location not to exceed 126 Locksets per Location.
- Up to 48 Locksets per port, wireless or hardwired with no limit to number of ports.
- Up to 7 Devices and 48 Locksets per LAN module. Unlimited LAN modules.
- Up to 14 Devices and 48 Locksets per USB/MCI module. Unlimited USB/MCI modules.
- All Addresses must be unique for every Lockset and PIM. AD-300 Wired Locksets require both a PIM and Lockset Address.
- PIM400-485s can support 1 – 16 Locksets. Actual Number is governed by RF coverage. In other words you may have fewer than 16 on a PIM due to environmental and RF communication constraints.
- RS-485 – 4-Wire RS-485. Be sure PIMS are configured correctly. Two twisted pairs up to 4000 feet between the L85 software and last device on port.
- Reader / Keypad wireless Locksets can be configured via WinDSX for Card, PIN, or Card + PIN.
- Do Not Use Cat5 cable except for TCP/IP communications.
- RS-485 requires 2 twisted pair 22ga.